



PARTS LIST FOR SC80910 SCALERS

Form Z659
Date 1-01/A
Page 1 of 1

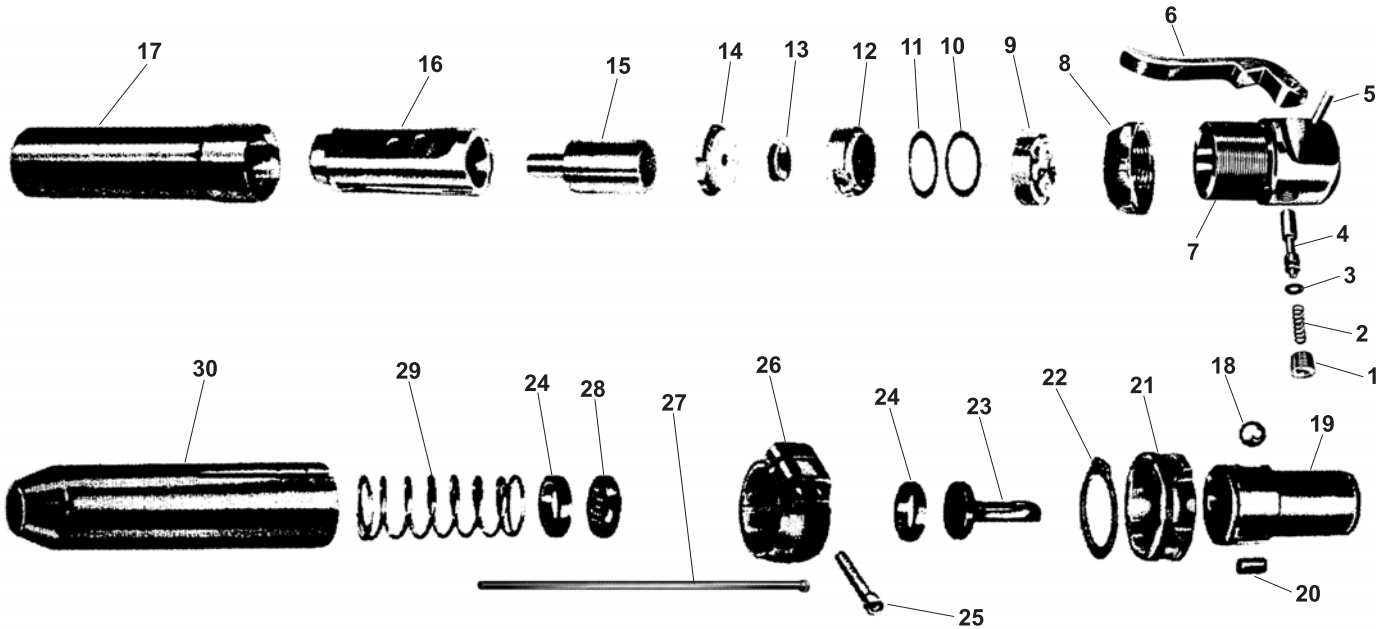

Fig. No.	Part No.	Description
1.	601985	Valve Plug
2.	602002	Valve Spring
3.	601993	"O" Ring
4.	602001	Throttle Valve
5.	601998	Pin
6.	601986	Throttle Lever
7.	602008	Backhead
8.	602007	Locknut
9.	602012	Spacer
10.	601997	Shim (.010")
11.	601996	Shim (.005")
12.	601988	Valve Lid
13.	601989	Cycling Valve
14.	601995	Cycling Valve Case
15.	601994	Piston
16.	601987	Cylinder Sleeve
17.	602013	Housing Cylinder

Fig. No.	Part No.	Description
18.	601992	Ball
19.	601990	Chisel Sleeve
20.	602000	Rubber Lock
21.	601999	Chisel Lock Ring
22.	601991	Retaining Ring
23.	602003	Anvil
24.	602006	Buffer Holder (2)*
25.	602011	Screw Socket Head (2)*
26.	602010	Housing Clamp
27.	2262	Needle Set of 19 (7" X .125)
28.	602004	Needle Holder
29.	602005	Needle Spring
30.	602009	Needle Housing

NOT SHOWN:
601858 Inlet Bushing 1/4" X 1/4" NPT

*Order Quantity As Required

FURNISH CATALOG, SERIAL, AND MODEL NUMBER
WHEN ORDERING PARTS

SIoux TOOLS INC.

250 SNAP-ON DRIVE ■ PO BOX 1596 ■ MURPHY, NC 28906 ■ USA ■

Printed In U.S.A.

This pdf incorporates the following model numbers:

SC80910AL-C

SC80910AL-K

SC80910AL-N5