

JET[®]

Operating Instructions and Parts Manual 7-inch Horizontal-Vertical Band Saw Model HVBS-7MW



WALTER MEIER (Manufacturing) Inc.

427 New Sanford Road
LaVergne, Tennessee 37086
Ph.: 800-274-6848
www.waltermeier.com

Part No. M-414459
Revision H 01/2012

Copyright © 2012 Walter Meier (Manufacturing) Inc.

1.0 Warranty and Service

Walter Meier (Manufacturing) Inc., warrants every product it sells. If one of our tools needs service or repair, one of our Authorized Service Centers located throughout the United States can give you quick service. In most cases, any of these Walter Meier Authorized Service Centers can authorize warranty repair, assist you in obtaining parts, or perform routine maintenance and major repair on your JET® tools. For the name of an Authorized Service Center in your area call 1-800-274-6848.

MORE INFORMATION

Walter Meier is consistently adding new products to the line. For complete, up-to-date product information, check with your local Walter Meier distributor, or visit waltermeier.com.

WARRANTY

JET products carry a limited warranty which varies in duration based upon the product (MW = Metalworking, WW = Woodworking).

90 DAY WARRANTY	1 YEAR WARRANTY	Body Repair Kits Bottle Jacks Cable Pullers Cold Saws Hoists-Air Hoists-Electric Metal forming Mill/Drills Milling Machines MW Bandsaws MW Drill Presses MW Finishing Equipment MW Lathes MW Precision Vises	2 YEAR WARRANTY	Palet Trucks Rigging Equip. Service Jacks Stackers Surface Grinders Tapping Trolleys-Air Trolleys-Electric Web Slings Winches-Electric	3 YEAR WARRANTY	WW Benchtop Tools	5 YEAR WARRANTY	Beam Clamps Chain Hoist-Manual Lever Hoists Pullers-JCH Models Scissor Lift Tables Screw Jacks Trolleys-Geared Trolleys-Plain Winches-Manual WW Air Filtration WW Bandsaws WW Buffers	WW Drill Presses WW Dust Collectors WW Dust Filters WW Dust Fittings WW Jointers WW Lathes WW Planers WW Sanders WW Shapers WW Tablesaws	LIFE LIFETIME WARRANTY	Fastening Tools Mechanics Hand Tools Striking Tools Vises (no -precision) Clamps
Warranty reverts to 1 Year Warranty if woodworking (WW) products listed above are used for industrial or educational purposes.											

WHAT IS COVERED?

This warranty covers any defects in workmanship or materials subject to the exceptions stated below. Cutting tools, abrasives and other consumables are excluded from warranty coverage.

WHO IS COVERED?

This warranty covers only the initial purchaser of the product.

WHAT IS THE PERIOD OF COVERAGE?

The general JET warranty lasts for the time period specified in the product literature of each product.

WHAT IS NOT COVERED?

Five Year Warranties do not cover woodworking (WW) products used for commercial, industrial or educational purposes. Woodworking products with Five Year Warranties that are used for commercial, industrial or education purposes revert to a One Year Warranty. This warranty does not cover defects due directly or indirectly to misuse, abuse, negligence or accidents, normal wear-and-tear, improper repair or alterations, or lack of maintenance.

HOW TO GET SERVICE

The product or part must be returned for examination, postage prepaid, to a location designated by us. For the name of the location nearest you, please call 1-800-274-6848.

You must provide proof of initial purchase date and an explanation of the complaint must accompany the merchandise. If our inspection discloses a defect, we will repair or replace the product, or refund the purchase price, at our option. We will return the repaired product or replacement at our expense unless it is determined by us that there is no defect, or that the defect resulted from causes not within the scope of our warranty in which case we will, at your direction, dispose of or return the product. In the event you choose to have the product returned, you will be responsible for the shipping and handling costs of the return.

HOW STATE LAW APPLIES

This warranty gives you specific legal rights; you may also have other rights which vary from state to state.

LIMITATIONS ON THIS WARRANTY

WALTER MEIER (MANUFACTURING) INC., LIMITS ALL IMPLIED WARRANTIES TO THE PERIOD OF THE LIMITED WARRANTY FOR EACH PRODUCT. EXCEPT AS STATED HEREIN, ANY IMPLIED WARRANTIES OR MERCHANTABILITY AND FITNESS ARE EXCLUDED. SOME STATES DO NOT ALLOW LIMITATIONS ON HOW LONG THE IMPLIED WARRANTY LASTS, SO THE ABOVE LIMITATION MAY NOT APPLY TO YOU.

WALTER MEIER SHALL IN NO EVENT BE LIABLE FOR DEATH, INJURIES TO PERSONS OR PROPERTY, OR FOR INCIDENTAL, CONTINGENT, SPECIAL, OR CONSEQUENTIAL DAMAGES ARISING FROM THE USE OF OUR PRODUCTS. SOME STATES DO NOT ALLOW THE EXCLUSION OR LIMITATION OF INCIDENTAL OR CONSEQUENTIAL DAMAGES, SO THE ABOVE LIMITATION OR EXCLUSION MAY NOT APPLY TO YOU.

Walter Meier sells through distributors only. The specifications in Walter Meier catalogs are given as general information and are not binding. Members of Walter Meier reserve the right to effect at any time, without prior notice, those alterations to parts, fittings, and accessory equipment which they may deem necessary for any reason whatsoever. JET® branded products are not sold in Canada by Walter Meier.

2.0 Table of contents

Section	Page
1.0 Warranty and Service	2
2.0 Table of contents	3
3.0 Safety warnings	4
4.0 About this manual	5
5.0 Specifications	6
6.0 Setup and assembly	7
6.1 Shipping contents.....	7
6.2 Unpacking and clean-up.....	7
6.3 Assembly	7
6.4 Vertical cutting plate.....	7
6.5 Coolant tank preparation	8
6.6 Electrical connections.....	8
6.7 Voltage conversion.....	9
6.8 Extension cords.....	9
7.0 Adjustments.....	10
7.1 Hydraulic feed selector.....	10
7.2 Changing blade speed.....	10
7.3 Adjusting blade guides	10
7.4 Vise adjustment.....	10
7.5 Blade tension	11
7.6 Changing blades	11
7.7 Adjusting blade square to table.....	12
7.8 Adjusting blade square to vise	12
7.9 Adjusting blade tracking	13
7.10 Adjusting blade guide bearings.....	13
7.11 Adjusting bow weight.....	14
7.12 Adjusting automatic shutoff.....	14
8.0 Operation.....	14
9.0 Maintenance	15
9.1 Lubrication	15
9.2 Chip Cleaning Brush	15
10.0 Replacement Parts	16
10.1.1 HVBS-7MW Bed Assembly – Exploded View.....	17
10.1.2 HVBS-7MW Bow Assembly – Exploded View	18
10.1.3 HVBS-7MW Bed and Bow Assemblies – Parts List.....	19
10.2.1 HVBS-7MW Cylinder Assembly – Exploded View	23
10.2.2 HVBS-7MW Cylinder Assembly – Parts List.....	23
11.0 Electrical Connections.....	24



3.0 Safety warnings

1. Read and understand the entire owner's manual before attempting assembly or operation.
2. Read and understand the warnings posted on the machine and in this manual. Failure to comply with all of these warnings may cause serious injury.
3. Replace the warning labels if they become obscured or removed.
4. This band saw is designed and intended for use by properly trained and experienced personnel only. If you are not familiar with the proper and safe operation of a band saw, do not use until proper training and knowledge have been obtained.
5. Do not use this machine for other than its intended use. If used for other purposes, Walter Meier (Manufacturing) Inc., disclaims any real or implied warranty and holds itself harmless from any injury that may result from that use.
6. Always wear approved safety glasses/face shields while using this table saw. *Everyday eyeglasses only have impact resistant lenses; they are not safety glasses.*
7. Before operating this band saw, remove tie, rings, watches and other jewelry, and roll sleeves up past the elbows. Remove all loose clothing and confine long hair. Non-slip footwear or anti-skid floor strips are recommended.
8. Wear ear protectors (plugs or muffs) during extended periods of operation.
9. Some dust created by power sanding, sawing, grinding, drilling and other construction activities contain chemicals known to cause cancer, birth defects or other reproductive harm. Some examples of these chemicals are:
 - Lead from lead based paint.
 - Crystalline silica from bricks, cement and other masonry products.
 - Arsenic and chromium from chemically treated lumber.

Your risk of exposure varies, depending on how often you do this type of work. To

reduce your exposure to these chemicals, work in a well-ventilated area and work with approved safety equipment, such as face or dust masks that are specifically designed to filter out microscopic particles.

10. Do not operate this machine while tired or under the influence of drugs, alcohol or any medication.
11. Make certain the switch is in the OFF position before connecting the machine to the power supply.
12. Make certain the machine is properly grounded.
13. Make all machine adjustments or maintenance with the machine unplugged from the power source.
14. Remove adjusting keys and wrenches. Form a habit of checking to see that keys and adjusting wrenches are removed from the machine before turning it on.
15. Keep safety guards in place at all times when the machine is in use. If removed for maintenance purposes, use extreme caution and replace the guards immediately after completion of maintenance.
16. Never hold the material with saw in horizontal position. Always use vise and clamp it securely.
17. Keep hands and fingers away from blade at all times during operation.
18. Provide adequate support for long and heavy material.
19. Check damaged parts. Before further use of the machine, a guard or other part that is damaged should be carefully checked to determine that it will operate properly and perform its intended function. Check for alignment of moving parts, binding of moving parts, breakage of parts, mounting and any other conditions that may affect its operation. A guard or other part that is damaged should be properly repaired or replaced.
20. Provide for adequate space surrounding work area and non-glare, overhead lighting.
21. Keep the floor around the machine clean and free of scrap material, oil and grease.
22. Keep visitors a safe distance from the work area. Keep children away.

23. Make your workshop child proof with padlocks, master switches or by removing starter keys.
24. Give your work undivided attention. Looking around, carrying on a conversation and “horse-play” are careless acts that can result in serious injury.
25. Maintain a balanced stance at all times so that you do not fall into the blade or other moving parts. Do not overreach or use excessive force to perform any machine operation.
26. Use the right tool at the correct speed and feed rate. Do not force a tool or attachment to do a job for which it was not designed. The right tool will do the job better and more safely.
27. Use recommended accessories; improper accessories may be hazardous.
28. Maintain tools with care. Keep saw blades sharp and clean for the best and safest performance. Follow instructions for lubricating and changing accessories.
29. Turn off the machine before cleaning. Use a brush or compressed air to remove chips or debris — do not use your hands.
30. Do not stand on the machine. Serious injury could occur if the machine tips over.
31. Never leave the machine running unattended. Turn the power off and do not leave the machine until it comes to a complete stop.
32. Remove loose items and unnecessary work pieces from the area before starting the machine.
33. Feed work into a blade or cutter against the direction of rotation of the blade or cutter only.
34. Don't use in dangerous environment. Don't use power tools in damp or wet location, or expose them to rain. Keep work area well lighted.
35. Familiarize yourself with the following safety notices used in this manual:
 - CAUTION** This means that if precautions are not heeded, it may result in minor injury and/or possible machine damage.
 - WARNING** This means that if precautions are not heeded, it may result in serious injury or possibly even death.

4.0 About this manual

This manual is provided by Walter Meier (Manufacturing) Inc. covering the safe operation and maintenance procedures for a JET Model HVBS-7MW Band Saw. This manual contains instructions on installation, safety precautions, general operating procedures, maintenance instructions and parts breakdown. Your machine has been designed and constructed to provide years of trouble-free operation if used in accordance with the instructions as set forth in this document.

If there are questions or comments, please contact your local supplier or Walter Meier. Walter Meier can also be reached at our web site: www.waltermeier.com.

Retain this manual for future reference. If the machine transfers ownership, the manual should accompany it.

WARNING Read and understand the entire contents of this manual before attempting assembly or operation! Failure to comply may cause serious injury!

5.0 Specifications

Model number	HBS-7MW
Stock number	414459
Capacity:	
Round at 90°	7" (178mm)
Round at 45°	4-1/2" (144mm)
Rectangle at 90°	2"H x 12"W (51x305mm); 7"H x 10-7/8"W (178 x 276mm)
Rectangle at 45°	7"H x 3-1/2"W (178 x 89mm); 5-1/2"H x 4-1/2"W (140 x 114mm)
Throat depth	7" (178mm)
Vertical worktable	9-3/8" x 10" (238 x 254mm)
Bed height from floor	23" (584mm)
Vise tilts	45°
Blade size	3/4" x 0.035" x 93" (19 x 0.889 x 2362mm)
Blade speed	86, 132, 178, 260 sfpm
Blade wheel diameter	11-3/4" (300mm)
Motor (UL listed)	TEFC, 3/4HP, 1PH, 115/230V (prewired 115V), 60Hz
Floor space required	49-1/2" L x 20-1/2" W x 41" H (1257 x 521 x 1041.5mm)
Net weight (approximate)	286 lb (130 kg)
Shipping weight (approximate)	331 lb (150 kg)

The specifications in this manual were current at time of publication, but because of our policy of continuous improvement, Walter Meier (Manufacturing) Inc., reserves the right to change specifications at any time and without prior notice, without incurring obligations.

6.0 Setup and assembly

6.1 Shipping contents

- 1 Band saw
- 2 Wheel axles
- 4 Wheels
- 4 Split pins
- 2 Strain clamps
- 1 Material stop bar
- 1 Material stop
- 1 Belt cover
- 1 Vertical cutting plate

Tools required for assembly:

- #2 cross point screwdriver
- Pliers

6.2 Unpacking and clean-up

1. Finish uncrating the saw. Inspect it for shipping damage. If any damage has occurred, contact your distributor.
2. Unbolt the saw from the skid and place it on a level surface.
3. Clean rust protected surfaces with kerosene, diesel oil, or a mild solvent. Do not use cellulose based solvents such as paint thinner or lacquer thinner. These will damage painted surfaces.

6.3 Assembly

1. Place blocking under the ends of the saw base to allow wheel installation. **Caution:** Make sure saw is steady while temporarily supported.
2. Slide wheel axles through the holes in the base.
3. Slide the wheels onto the axles and fasten with pins. Bend the pins to hold in place.
4. Slide material stop bar (A, Figure 1) into the base and secure by tightening bolt (B, Figure 1). Slide material stop (C, Figure 1) onto the bar and tighten bolt (D, Figure 1).
5. Slide belt cover over pulley assemblies and fasten with screws and washers (A, Figure 2).
6. Close belt cover and secure with lock knob (B, Figure 2).
7. Remove transportation strap which holds the bow to the bed, and keep it for later use should the saw be moved any distance.

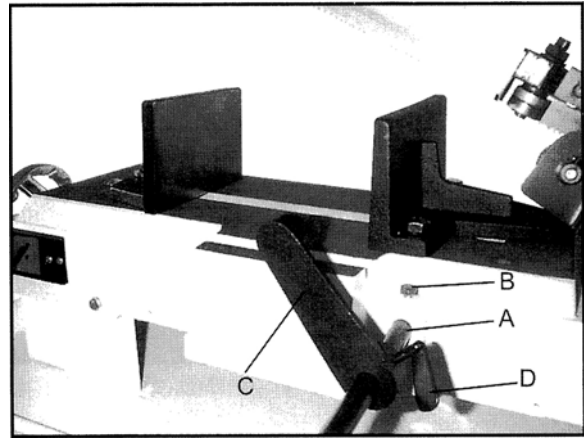

Figure 1

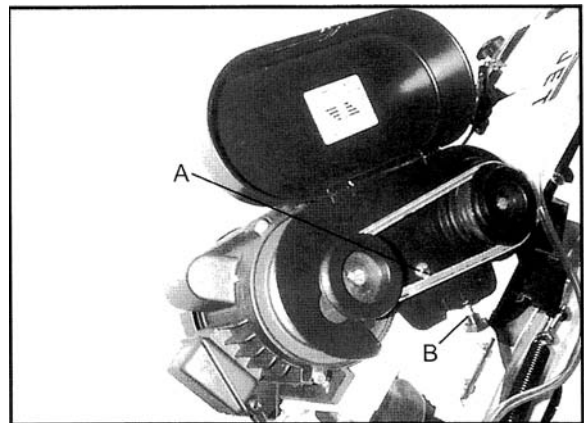

Figure 2

6.4 Vertical cutting plate

Note: These steps are only necessary if using the band saw in vertical mode.

WARNING Disconnect machine from power source before making repairs or adjustments.

1. Disconnect band saw from power source.
2. Raise bow to vertical position by turning the bow stop (A, Figure 3) a quarter turn clockwise; slowly bring bow to vertical and lock in place by turning the hydraulic cylinder valve to the off position. **Caution: Do not pinch fingers between bow stop and bracket.**
3. Remove two screws (A, Figure 4) and remove deflector plate (B, Figure 4).
4. Guide blade through the slot in the table and fasten with two screws. See Figure 5.
5. When vertical operations are completed, to lower bow turn hydraulic cylinder lever to on position.

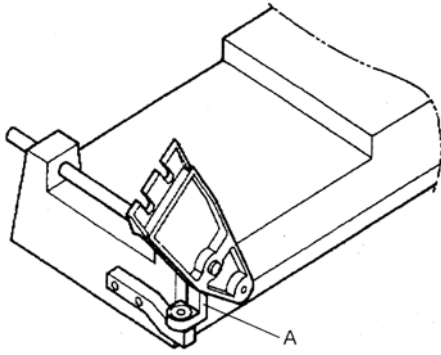

Figure 3

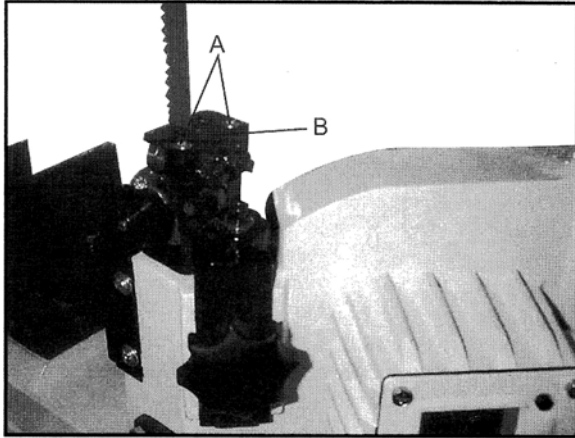

Figure 4

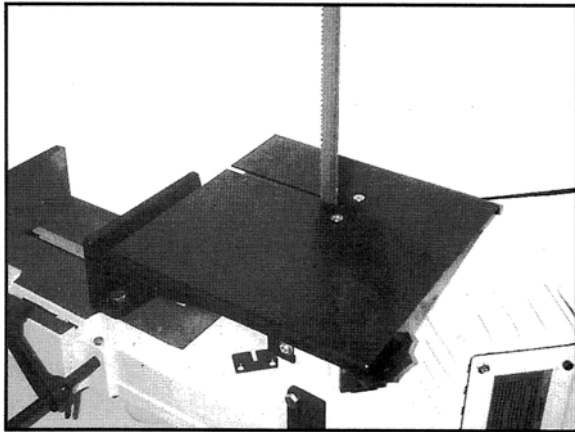

Figure 5

6.5 Coolant tank preparation

Use of a water-soluble coolant will increase cutting efficiency and prolong blade life. Do not use black cutting oil as a substitute. Change cutting oil often and follow manufacturer's instructions as to its uses and precautions.

1. Disconnect machine from power source.
2. Remove coolant return hose from the tank cover.
3. Slide tank out of saw base and carefully remove the lid containing the coolant pump.

4. Fill tank to approximately 80% of capacity.
5. Place lid back onto tank, and place tank assembly back into base.
6. Replace return hose back into the hole in the tank lid.

6.6 Electrical connections

⚠WARNING Electrical connections must be made by a qualified electrician in compliance with all relevant codes. This machine must be properly grounded to help prevent electrical shock and possible fatal injury.

1. All Grounded, Cord-connected Tools:

In the event of a malfunction or breakdown, grounding provides a path of least resistance for electric current to reduce the risk of electric shock. This tool is equipped with an electric cord having an equipment-grounding conductor and a grounding plug. The plug must be plugged into a matching outlet that is properly installed and grounded in accordance with all local codes and ordinances.

Do not modify the plug provided - if it will not fit the outlet, have the proper outlet installed by a qualified electrician.

Improper connection of the equipment-grounding conductor can result in a risk of electric shock. The conductor with insulation having an outer surface that is green with or without yellow stripes is the equipment-grounding conductor. If repair or replacement of the electric cord or plug is necessary, do not connect the equipment-grounding conductor to a live terminal.

⚠WARNING Check with a qualified electrician or service personnel if the grounding instructions are not completely understood, or if in doubt as to whether the tool is properly grounded. Failure to comply may cause serious or fatal injury.

Use only 3-wire extension cords that have 3-prong grounding plugs and 3-pole receptacles that accept the tool's plug.

Repair or replace damaged or worn cord immediately.

2. Grounded, cord-connected tools intended for use on a supply circuit having a nominal rating less than 150 volts:

This tool is intended for use on a circuit that has an outlet that looks like the one illustrated in **A**, Figure 6. An adapter, shown in **B** and **C**, may be

used to connect this plug to a 2-pole receptacle as shown in **B** if a properly grounded outlet is not available. The temporary adapter should be used only until a properly grounded outlet can be installed by a qualified electrician. *This adapter is not permitted in Canada.* The green-colored rigid ear, lug, and the like, extending from the adapter must be connected to a permanent ground such as a properly grounded outlet box.

3. *Grounded, cord-connected tools intended for use on a supply circuit having a nominal rating between 150 - 250 volts, inclusive:*

This tool is intended for use on a circuit that has an outlet that looks like the one illustrated in **D**, Figure 6. The tool has a grounding plug that looks like the plug illustrated in **D**. Make sure the tool is connected to an outlet having the same configuration as the plug. No adapter is available or should be used with this tool. If the tool must be reconnected for use on a different type of electric circuit, the reconnection should be made by qualified service personnel; and after reconnection, the tool should comply with all local codes and ordinances.

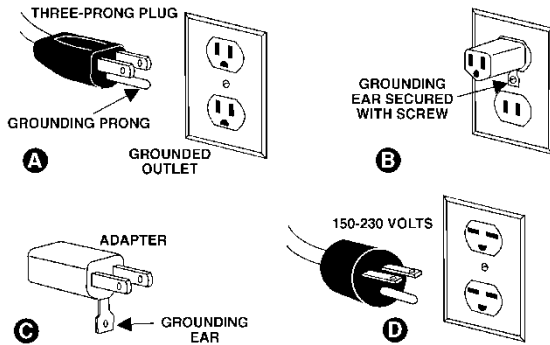

Figure 6

6.7 Voltage conversion

The HVBS-7MW band saw is rated at 115/230V and comes from the factory prewired at 115V. To switch to 230V operation, follow the wiring diagram found on the inside of the motor junction box. (Similar diagrams are shown in Figures 7/8.) The plug must be replaced with a plug that is rated at 230V. The coolant pump wiring will have to be changed also. Follow the diagram found on the coolant pump head to switch to 230V operation.

Before hooking up to the power source, be sure the power and coolant switches are in the off position.

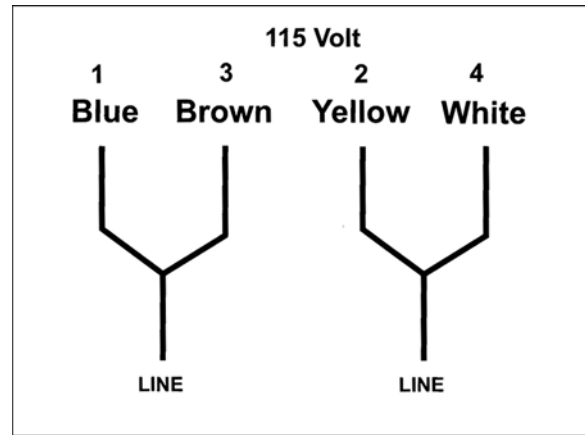

Figure 7

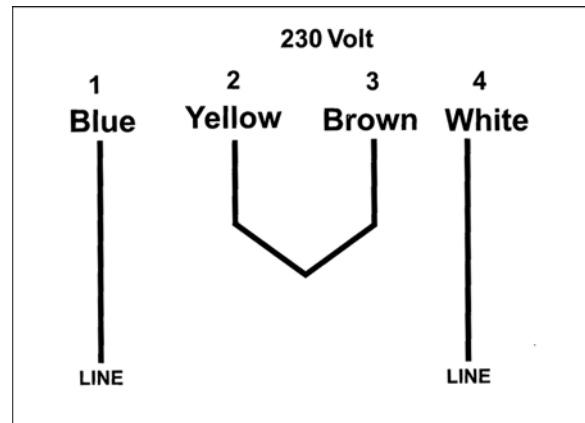

Figure 8

6.8 Extension cords

The use of extension cords is discouraged. Try to position machines within reach of the power source. If an extension cord becomes necessary, make sure the cord is in good condition and heavy enough to carry the current your product will draw. An undersized cord will cause a drop in line voltage resulting in loss of power and overheating. Table 1 shows correct size to use depending on cord length and nameplate ampere rating. If in doubt, use the next heavier gauge. The smaller the gauge number, the heavier the cord.

Ampere Rating		Volts	Total length of cord in feet			
More Than	Not More Than		25	50	100	150
		120 240	25	50	100	150
			AWG			
0	6		18	16	16	14
6	10		18	16	14	12
10	12		16	16	14	12
12	16		14	12	Not Recommended	

Extension Cord Recommendations
Table 1

7.0 Adjustments

7.1 Hydraulic feed selector

The hydraulic feed selector is used to control the blade feed rate and to lock the bow in vertical position. To increase feed rate, turn knob (A, Figure 9) counter-clockwise. To decrease feed rate, turn knob (A) clockwise. To turn off flow of hydraulic fluid, turn lever (B) as shown in Figure 9. To turn hydraulic cylinder on, raise lever (B) to the 12 o'clock position.

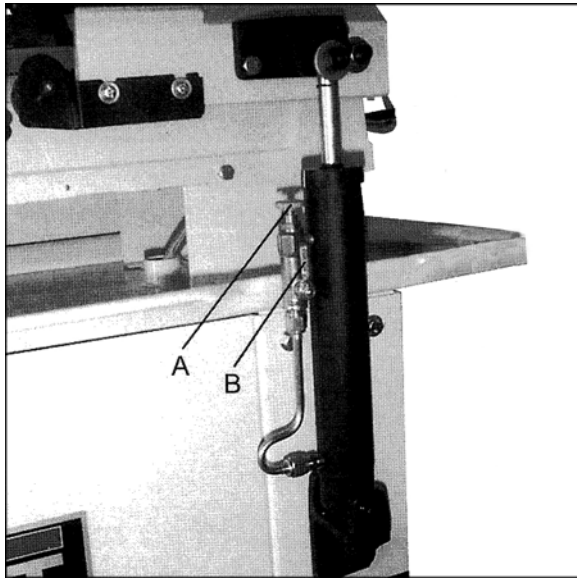

Figure 9

7.2 Changing blade speed

1. Disconnect machine from power source.
2. Loosen motor plate lock bolt (A, Figure 10).
3. Loosen motor plate slide bolt (B, Figure 10) until the belt can be moved on the pulleys.
4. Move belt to desired pulley combination.
5. Tighten motor plate slide bolt (B) to re-tension belt.
6. Tighten motor plate lock bolt (A).
7. Connect machine to power source.

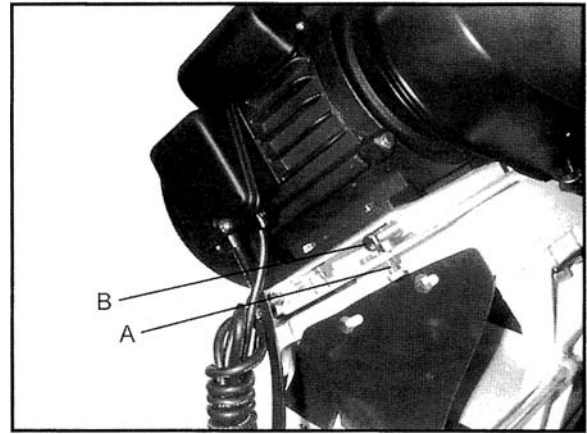

Figure 10

7.3 Adjusting blade guides

1. Disconnect machine from power source.
2. Loosen knob (A, Figure 11) and bolt (B, Figure 11). Slide blade guide assemblies as close as possible to material without interfering with the cut.
3. Tighten knob (A, Figure 11) and bolt (B, Figure 11) and connect machine to power source.

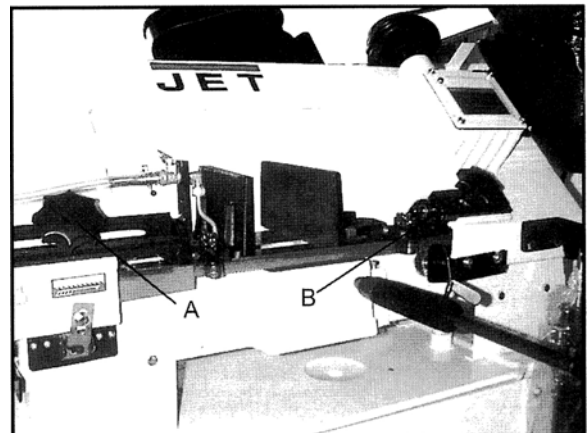

Figure 11

7.4 Vise adjustment

WARNING Do not make any adjustments or load/unload material from vise while machine is running. Failure to comply may cause serious injury.

To set the vise for 0 to 45 degree cutting:

1. Remove bolt and nut assemblies (C, Figure 12).
2. Position the vise and re-install as pictured in Figure 13. Pay particular attention to the bolt hole location.

3. Set vise to desired angle, re-install nuts and bolts, and tighten the nut and bolt assemblies.
4. Adjust the movable vise parallel to the fixed vise by loosening bolt (A, Figure 13), adjusting to parallel, and tightening bolt.

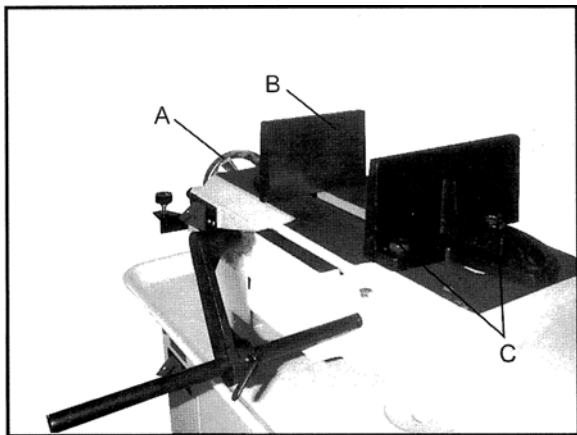

Figure 12

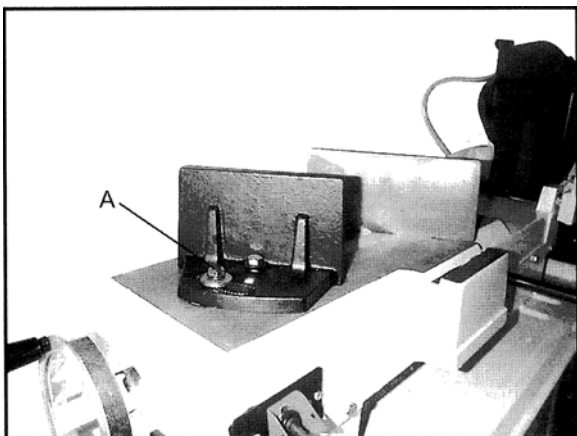

Figure 13

To set vise for maximum width of stock cutting:

1. Remove the nut and bolt assemblies.
2. Position the vise and re-install the bolt assemblies as pictured in Figure 12.

7.5 Blade tension

⚠WARNING Disconnect machine from power source. Blades are sharp; use extra care when removing, installing or adjusting. Failure to comply may cause serious injury.

Blade tension is important to the proper operation of the saw. Proper blade tension is 22,000 to 25,000 lbs. per square inch as measured on a blade tension gauge.

To set the blade tension without the use of a blade tension gauge:

1. Install blade between the wheels, and insert blade between the bearings on the blade guides.
2. Tension blade slightly to remove any sag in blade between blade wheels.
3. Turn blade tension knob (A, Figure 14) one and three quarter to two revolutions clockwise. This equals approximately 23,000 lbs. of blade tension.

⚠CAUTION Do not overtighten blade. This may cause blade to stretch and warp.

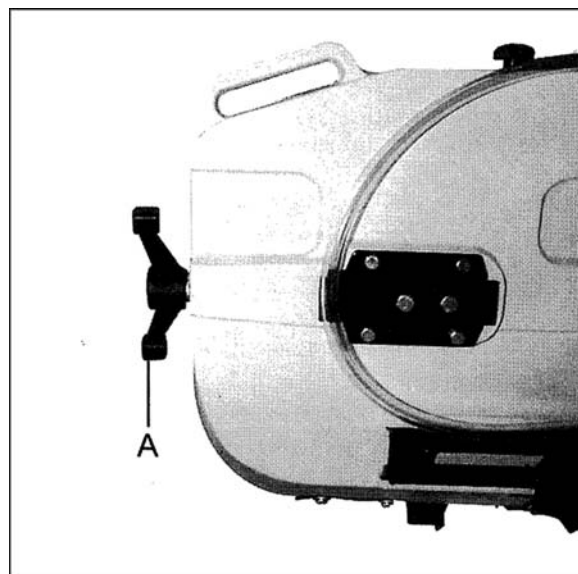

Figure 14

4. After blade has been completely installed, close the covers, connect to power source, and run saw for two to three minutes so the blade can seat properly.
5. Disconnect machine from power source. Open the cover and loosen blade just until it begins to sag.
6. Tighten blade until it becomes straight between the blade wheels and all sag has been eliminated.
7. Tighten blade by turning blade tension wheel two full revolutions. Blade is now properly tensioned and ready for use.
8. Close the covers and connect machine to power source.

7.6 Changing blades

⚠WARNING Never operate this saw unless all blade guards are installed and in proper working order. Never adjust blade brush while machine is running.

CAUTION This machine is designed and intended for use with blades that are 3/4" wide by 0.032" thick x 93" long. Use of blades with difference specifications may cause inferior performance.

1. Disconnect machine from power source.
2. Raise bow to vertical position and lock in place by turning the hydraulic cylinder off.
3. Remove red blade guard assembly (A, Figure 15) by removing two screws (B, Figure 15).

WARNING It is essential this guard be installed after the new blade has been fitted.

4. Remove brush assembly (C, Figure 15) by removing two screws (D, Figure 15).

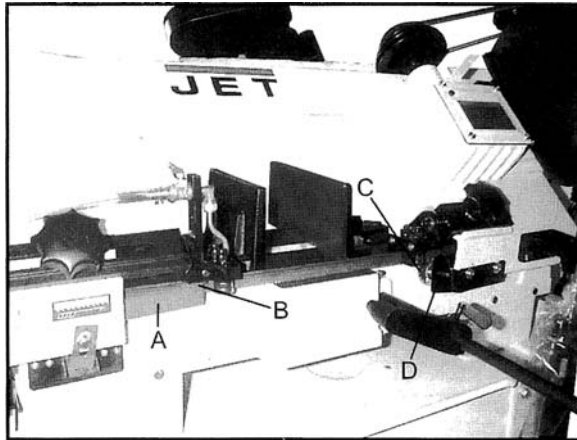

Figure 15

5. Loosen blade tension by turning blade tension knob counter-clockwise.
6. Carefully remove old blade. **Caution: blade teeth are sharp. Handle with care.**
7. Install new blade by placing the blade between blade guides first. Make sure the blade teeth face the same direction as indicated on the label found on the saw bow.
8. Place the blade around both wheels. Make sure the blade edge rests near the wheel flange on both wheels.
9. Turn the blade tension knob clockwise to tension the blade. Do not over tension. See section 7.5, *Blade tension*.
10. Close blade cover door and secure with lock knobs.
11. Attach red blade guard and brush assembly.
12. Connect machine to power source.

13. Run the saw and make sure blade is tracking properly (see section 7.9).

7.7 Adjusting blade square to table

1. Disconnect machine from power source.
2. Place a machinist's square on the table and against the blade, as shown in Figure 16.
3. Verify that blade makes contact with square along the entire width of blade.
4. If adjustment is necessary, loosen bolts (A, Figure 16) and rotate blade guide assemblies slightly in the same direction until the blade makes contact with the square along its entire width.
5. Tighten bolts (A, Figure 16).
6. Connect machine to power source.

Note: If adjustment to square blade to table is necessary, be sure to check blade adjustments again.

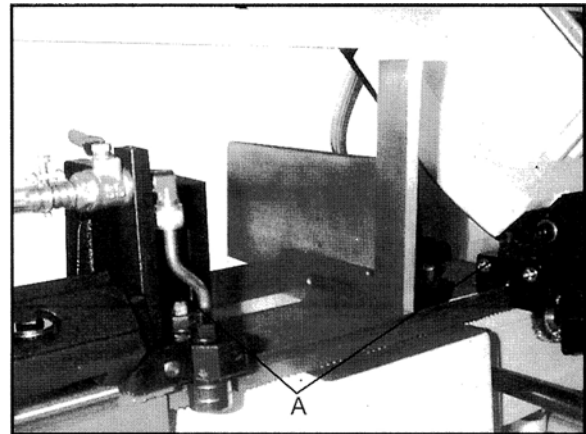

Figure 16

7.8 Adjusting blade square to vise

1. Disconnect machine from power source.
2. Place a machinist's square flush against vise and blade, as shown in Figure 17. Square should lie along the entire length of vise and blade without a gap.
3. If adjustment is necessary, loosen the bolts holding the vise and adjust the vise so that the square lines up properly. Tighten bolts.
4. Connect machine to power source.

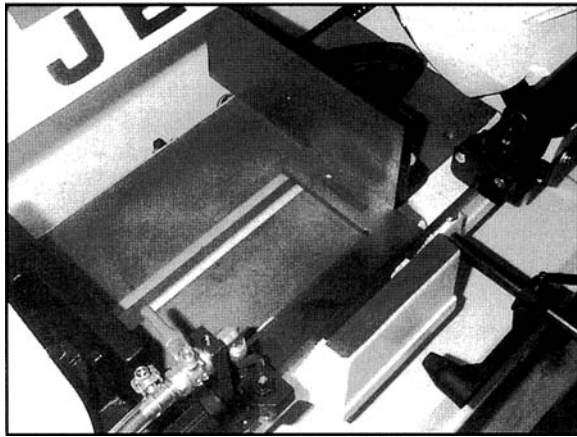

Figure 17

7.9 Adjusting blade tracking

⚠WARNING Blade tracking adjustment requires running the saw with the back cover open. This adjustment must be completed by qualified persons only.

Note: Before making any tracking adjustments, try a new blade. Warped blades will not track.

Blade tracking has been set at the factory and should not require adjustment. If tracking problems occur, adjust the machine as follows:

1. Move saw bow to vertical position and lock in place by shutting off hydraulic cylinder valve.
2. Confirm that blade tension is set properly. To adjust, see section 7.5, *Blade tension*.
3. Open back cover by loosening lock knobs.
4. Run the saw and observe the blade. Blade should run next to but not tightly against wheel flange.
5. Loosen bolts (A, Figure 18).
6. Turn set screw (B, Figure 18) while observing the blade tracking on the wheel. Turn set screw clockwise to track the blade closer to the wheel flange. Turn set screw counter-clockwise to track blade away from wheel flange.
7. Once tracking is set, tighten bolts (A, Figure 18).

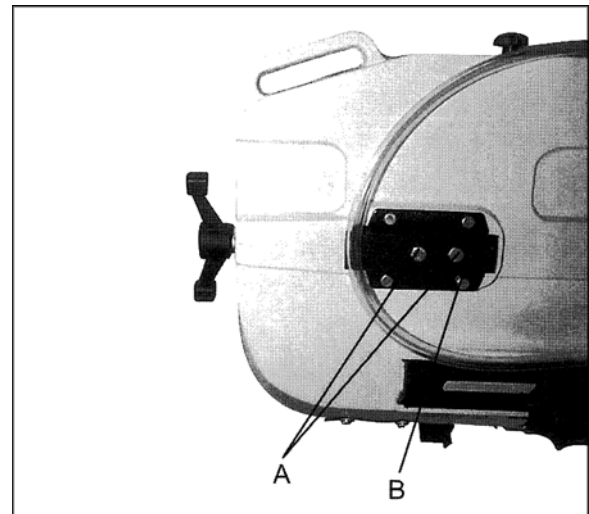

Figure 18

7.10 Adjusting blade guide bearings

1. Disconnect machine from power source.
2. Raise bow to vertical position and lock in place by turning off hydraulic cylinder valve.
3. Loosen hex cap screw (A, Figure 19) and adjust assembly so that the back roller bearing is approximately 0.003" to 0.005" from the back of the blade.
4. Turn nut (B, Figure 19) to adjust the eccentric bearing snug to the blade. Blade should still move up and down freely when grasped as in Figure 20. **Warning! Make sure power is disconnected and hands are protected before handling blade.** Be sure that the blade teeth do not interfere with the roller bearings.
5. Repeat for other blade guide assembly.
6. Connect machine to power source.

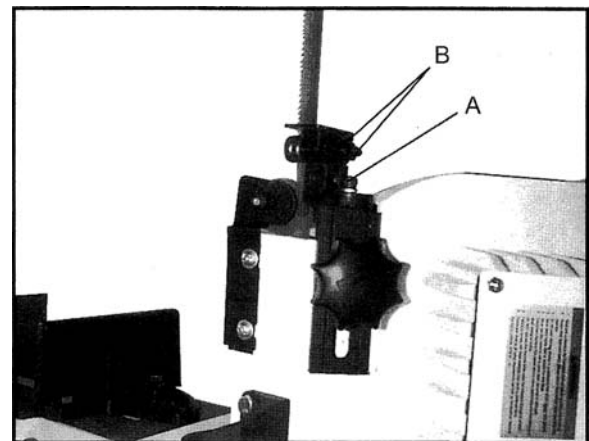

Figure 19

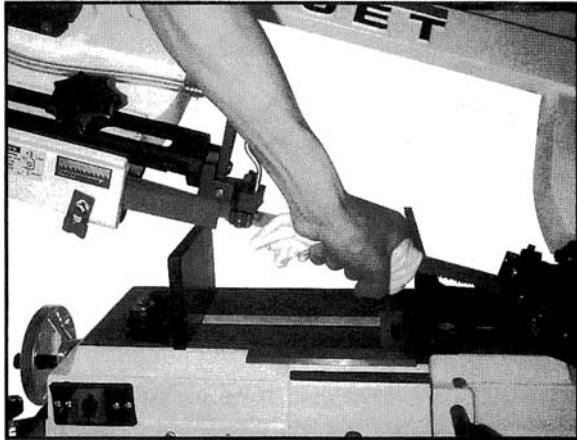

Figure 20

7.11 Adjusting bow weight

Bow weight is one of the most important adjustments of the saw. If bow weight is not set properly, one can expect poor performance, crooked cuts, tooth stripping, stalling, and the blade popping off the blade wheels. The hydraulic feed rate unit will not compensate for improper bow weight. Bow weight has been set at the factory and should not need adjustment.

If adjustment becomes necessary:

1. Disconnect machine from power source.
2. Turn on hydraulic cylinder valve and place the saw bow in horizontal position.
3. Turn feed rate valve on hydraulic cylinder counter-clockwise until it stops.
4. Place a fish-type scale under the blade tension handle and lift the saw bow. Scale should indicate approximately 13 to 15 lbs.
5. Adjust tension to approximately 13 to 15 lbs. by turning bolt (A, Figure 21).
6. Connect machine to power source.

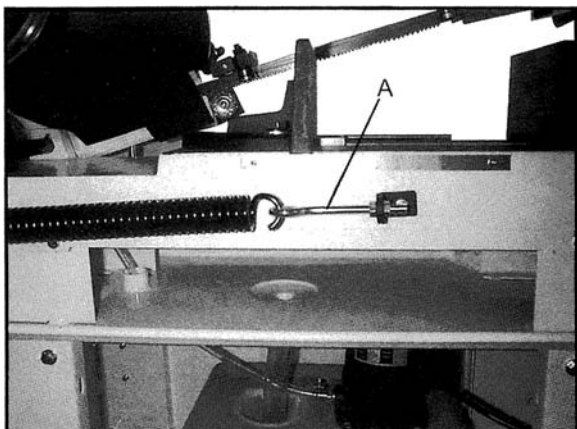

Figure 21

7.12 Adjusting automatic shutoff

The saw should stop after the cut has been completed:

1. If the saw completes the cut and continues to run, adjust the trip bracket (A, Figure 22) down.
2. If the saw shuts off before the cut is complete, adjust the trip bracket (A, Figure 22) up.
3. If the saw stops cutting but continues to run, adjust the stop bolt (B, Figure 22).

The saw is properly adjusted when the saw shuts off just after the blade has finished the cut.

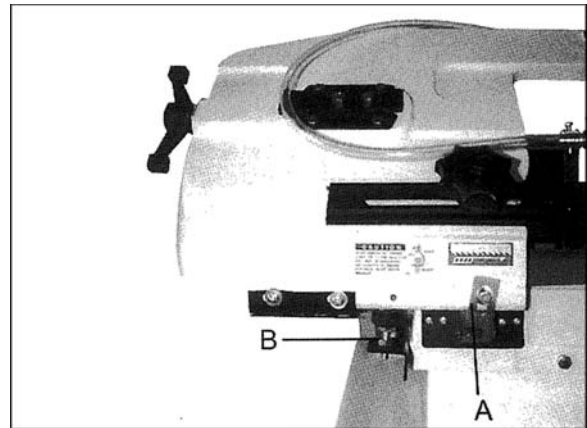

Figure 22

8.0 Operation

Prior to Operation:

1. Check to see that the blade tooth direction matches the diagram on saw body.
2. Check to see that the blade is properly seated on the wheels after proper tension has been applied.
3. Set the blade guide roller bearings snug against blade. See section 7.10, *Adjusting blade guide bearings*, for more detail.
4. Check for a slight clearance between the backup rollers and the back of the blade.
5. Position both blade guides as close to work as possible.
6. Select proper speed and feed rate for material being cut.
7. Material to be cut must be held securely in vise.
8. Check to see that coolant level is adequate.
9. Do not start a cut on a sharp edge.

10. Keep machine lubricated. See *section 9.1, Lubrication*.

9.0 Maintenance

⚠WARNING Disconnect machine from power source before making any repair or adjustment. Failure to do this may result in serious personal injury.

1. Keep all surfaces clean and free of rust, slag, chips, and coolant build-up.
2. Do not use compressed air to clean the band saw. Compressed air may force chips into the guide bearings and other critical areas of the saw.
3. Use a small paint brush or parts cleaning brush to remove metal particles.
4. Wipe the saw down with a clean, dry cloth and oil all unpainted surfaces with light machine oil.
5. Keep the blade guides clean and free of metal chips.
6. Check the guide bearings frequently to make sure they are properly adjusted and turning freely.

9.1 Lubrication

Ball bearings on the blade guide assemblies and the blade wheels are permanently sealed and require no lubrication.

Lightly lubricate the vise screw with #2 tube grease.

Change gear box oil after the first 90 days of operation. Thereafter, change every six months.

To change gear box oil:

1. Disconnect machine from power source.
2. Place saw bow in horizontal position.
3. Remove screws (A, Figure 23) from gear box and remove cover plate and gasket.

4. Hold a container under the lower right corner of the gear box with one hand while slowly raising the saw bow with the other.
5. Place the saw bow in horizontal position again. Wipe out remaining oil with a rag.
6. Fill the gear box with approximately 3/4 pint of 90 weight gear oil.
7. Replace the gasket and cover. Fasten the cover with screws.
8. Connect machine to the power source.

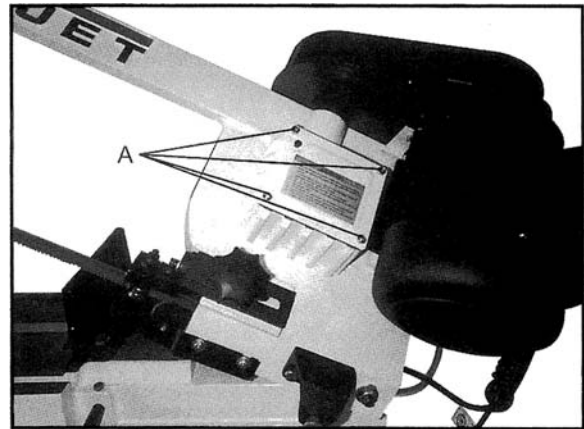

Figure 23

9.2 Chip Cleaning Brush

⚠WARNING Do not attempt to adjust blade brush with machine running. Adjust only when machine's power cord has been removed from power source.

It is very important that the blade cleaning brush be properly adjusted and kept in good working order. Replace the brush if it becomes damaged or worn out. Blade life will be shortened severely if the brush is allowed to go out of adjustment, becomes damaged, or is worn out.

10.0 Replacement Parts

Replacement parts are listed on the following pages. To order parts or reach our service department, call 1-800-274-6848 Monday through Friday (see our website for business hours, www.waltermeier.com). Having the Model Number and Serial Number of your machine available when you call will allow us to serve you quickly and accurately.

10.1.1 HVBS-7MW Bed Assembly – Exploded View

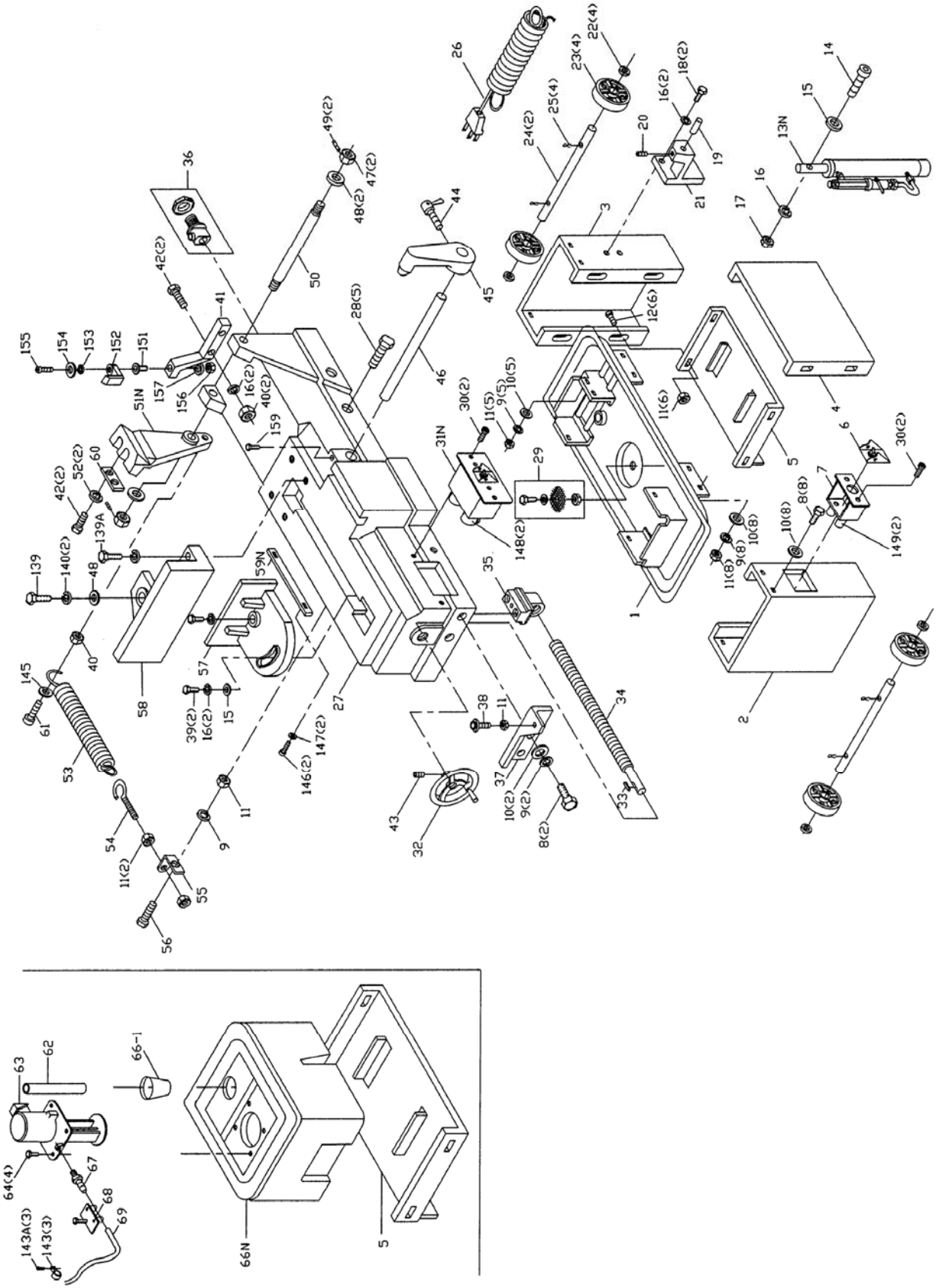

10.1.2 HVBS-7MW Bow Assembly – Exploded View

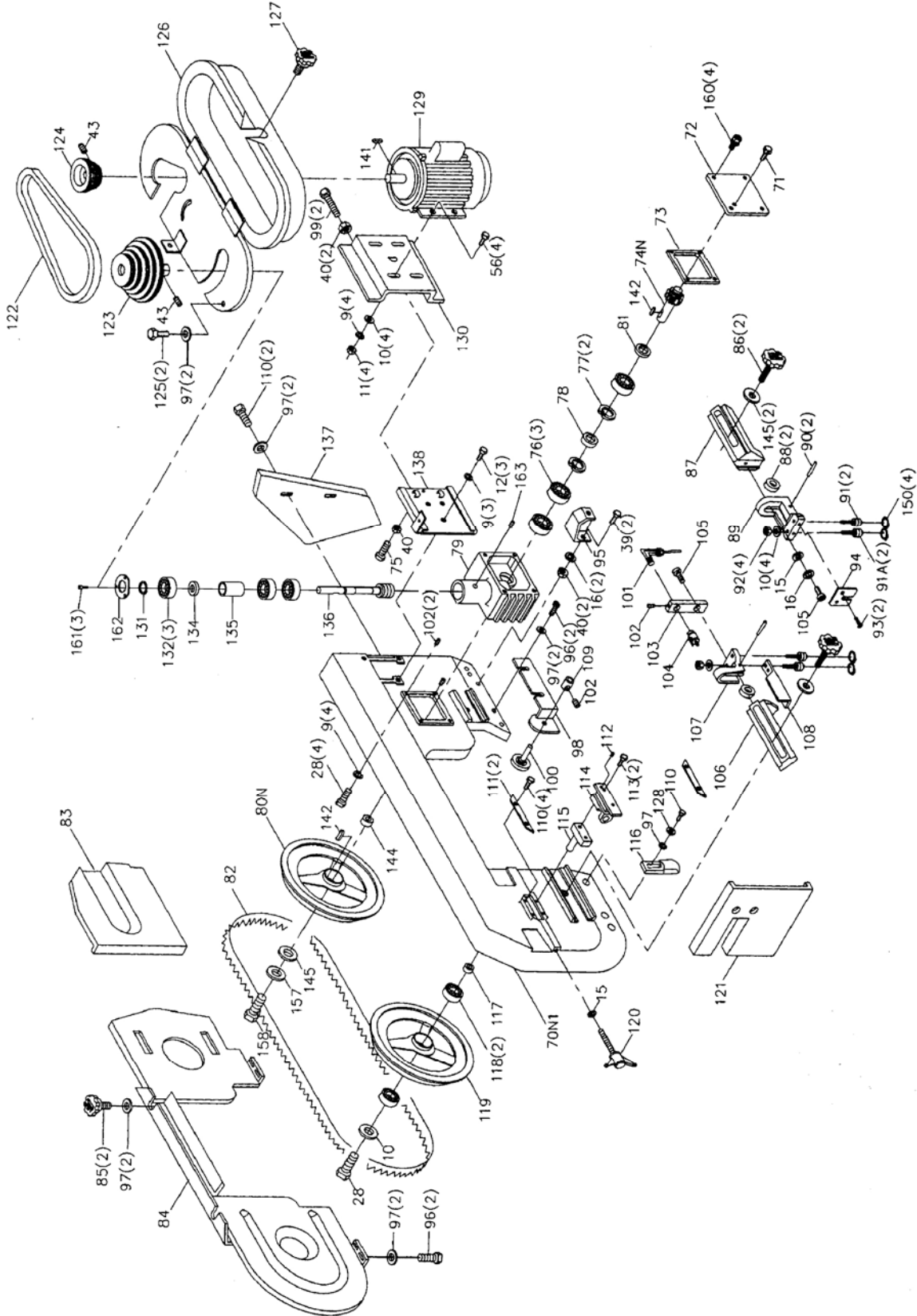

10.1.3 HVBS-7MW Bed and Bow Assemblies – Parts List

Index No	Part No	Description	Size	Qty
1	HVBS7MW-1	Coolant Pan		1
2	HVBS7MW-2	Base Leg (left)		1
3	HVBS7MW-3	Base Leg (right)		1
4	HVBS7MW-4	Skirt		1
5	HVBS7MW-5	Shelf		1
6	HVBS7MW-6	Toggle Switch		1
7	HVBS7MW-7	Electrical Box		1
8	TS-0051031	Hex Cap Bolt	5/16"x3/4"	10
9	TS-0720081	Lock Washer	5/16"	27
10	TS-0680031	Flat Washer	5/16"	32
11	TS-0561021	Hex Nut	5/16"	27
12	TS-0051011	Hex Cap Bolt	5/16"x1/2"	9
13	HVBS7MW-13	Cylinder Assembly (S/N: 010218160 and lower)		1
13N	HVBS7MW-13N	Cylinder Assembly (S/N: 010218161 and higher)		1
	HVBS7MW-13-RK	Cylinder Repair Kit (not shown)		1
14	TS-150506	Hex Socket Cap Screw **	M10x40	1
15	TS-0680041	Flat Washer **	3/8"	4
16	TS-0720091	Lock Washer **	3/8"	10
17	TS-154007	Hex Nut **	M10	1
18	TS-0060051	Hex Cap Bolt **	3/8"x1"	2
19	HVBS7MW-19	Support Rod **		1
20	TS-0050011	Hex Cap Bolt **	1/4"x1/2"	1
21	HVBS7MW-21	Bottom Support **		1
22	5518228N	Flat Washer (S/N: 120141912 and higher)	23.8x13x2.7mm	4
23	HVBS7MW-23	Wheel (S/N: 120141911 and lower)	4"	4
23N	5518229N	Wheel (S/N: 120141912 and higher)	8"	4
24	HVBS7MW-24	Wheel Shaft (S/N: 120141911 and lower)		
24N	5518230N	Wheel Shaft (S/N: 120141912 and higher)	Ø16x432mm	2
25	5518231N	Cotter Pin (S/N: 120141912 and higher)		4
	J3410-WA	Wheel Assembly (index # 22-25) (S/N: 120141912 and higher)		1
26	HVBS7MW-26	Power Cord		1
	HVBS7MW-26-1	Power Cord (motor - main switch –not shown)		1
	HVBS7MW-26-2	Power Cord (main switch - pump - not shown)		1
27	HVBS7MW-27	Table		1
28	TS-0081051	Hex Cap Bolt	5/16"x1"	10
29	HVBS7MW-29	Filter Assembly		1
30	HVBS7MW-30	Hex Head Screw	3/16"x3/8"	4
31	HVBS7MW-31	Switch Box Assembly (S/N: 5011368 & lower)		1
31N	HVBS7MW-31N	Switch Box Assembly (S/N: 5011369 & higher)		1
	HVBS7MW-31A	Switch (S/N: 5011368 & lower)		1
	HVBS7MW-31AN	Switch (S/N: 5011369 & higher)		1
32	HVBS7MW-32	Wheel Handle		1
33	HVBS7MW-33	Key	5x20mm	1
34	HVBS7MW-34	Lead Screw		1
35	HVBS7MW-35	Nut Seat		1
36	HVBS7MW-36	Strain Relief Assembly		1
37	HVBS7MW-37	Support Plate		1
38	HVBS7MW-38	Stop Screw		1
39	TS-0060061	Hex Cap Bolt **	3/8"x1-1/4"	4
40	TS-0561031	Nut **	3/8"	8
41	HVBS7MW-41	90° Support		1
42	TS-0060071	Hex Cap Bolt	3/8"x1-1/2"	4
43	TS-0270031	Set Screw	5/16"x3/8"	4
44	HVBS7MW-44	Thumb Screw		1
45	HVBS7MW-45	Stop Block		1

Index No	Part No	Description	Size	Qty
46	HVBS7MW-46	Stop Rod		1
47	TS-0561031	Hex Nut	1/2"	2
48	TS-0680061	Flat Washer	1/2"	4
49	TS-026702	Set Screw	1/4"x1/4"	2
50	HVBS7MW-50	Support Shaft		1
51	HVBS7MW-51	Pivot Arm (S/N: 80910746 and lower)		1
51N	HVBS7MW-51N	Pivot Arm (S/N: 80910747 and higher)		1
52	TS-0720091	Lock Washer	3/8"	2
53	HVBS7MW-53	Spring		1
54	HVBS7MW-54	Spring Adjusting Rod		1
55	HVBS7MW-55	Spring Bracket		1
56	TS-0051061	Hex Cap Bolt	5/16"x1-1/2"	5
57	HVBS7MW-57	Vise Jaw (left)		1
58	HVBS7MW-58	Vise Jaw (right)		1
59	HVBS7MW-59	Scale (S/N: 010217984 and lower)		1
59N	HVBS7MW-59N	Scale (S/N: 010217985 and higher)		1
60	HVBS7MW-60	Arm Support Plate		1
61	TS-020908	Hex Socket Cap Screw	3/8"x1-3/4"	1
62	HVBS7MW-62	Hose		1
63	HVBS7MW-63	Pump		1
64	TS-0050021	Hex Cap Bolt *	1/4"x5/8"	4
65	HVBS7MW-65	Tank Cover (S/N: 8091100 and lower)		1
66	HVBS7MW-66	Coolant Tank (S/N: 8091100 and lower)		1
66N	HVBS7MW-66N	New Coolant Tank (S/N:80911001 and higher)		1
66-1	HVBS7MW-66-1N	Plastic Funnel (S/N: 80911001 and higher)		1
67	HVBS7MW-67	Hose Fitting		1
68	HVBS7MW-68	Hose Clamp		1
69	HVBS7MW-69	Hose		1
70	HVBS7MW-70	Saw Bow (S/N: 8091100 and lower)		1
70N	HVBS7MW-70N	Saw Bow (S/N: 8091101 and higher)		1
70N1	HVBS7MW-70N1	Saw Bow (JET Mark) (S/N: 010218161 and higher)		1
71	HVBS7MW-71	Vent Plug *		1
72	HVBS7MW-72	Gear Box Cover *		1
73	HVBS7MW-73	Gear Box Gasket *		1
74	HVBS7MW-74	Worm Gear *(S/N: 00114808 and lower)		1
74N	HVBS7MW-74N	Worm Gear *(S/N: 00114809 and higher)		1
75	TS-051061	Hex Cap Bolt *	5/16"x1-1/4"	1
76	BB-6005Z	Ball Bearing *		3
77	HVBS7MW-77	C-Ring *	R-47	2
78	HVBS7MW-78	Oil Seal *		1
79	HVBS7MW-79	Gear Box *		1
80	HVBS7MW-80	Blade Wheel (S/N: 00114808 and lower)		1
80N	HVBS7MW-80N	Blade Wheel (S/N: 00114809 and higher)		1
81	HVBS7MW-81	Worm Bushing *		1
82	HVBS7MW-82	Bi-Metal Blade		1
83	HVBS7MW-83	Wheel Cover		1
84	HVBS7MW-84	Rear Wheel Cover		1
85	HVBS7MW-85	Plum Screw		2
86	HVBS7MW-86	Lock Knob		2
87	HVBS7MW-87	Adjustable Bracket (right)		1
88	BB-608ZZ	Ball Bearing		2
89	HVBS7MW-89	Adjustable Blade Seat (right)		1
90	HVBS7MW-90	Bearing Pin		2
91	HVBS7MW-91	Eccentric Shaft Assembly (outside)		2
91A	HVBS7MW-91A	Center Shaft Assembly(inside)(S/N: 80910747 and higher)		2
	BB-608ZZ	Ball Bearing (not shown)		8
	HVBS7MW-91-2	Eccentric Shaft (outside) (not shown)		2

Index No	Part No	Description	Size	Qty
	HVBS7MW-91A-2	Center Shaft (inside)(S/N: 80910747 and higher)		2
	HVBS7MW-91-3	C-Ring (<i>not shown</i>)		4
92	TS-0561031	Hex Nut	3/8"	4
93	TS-081F021	Flat Head Machine Screw	1/4"x3/8"	2
94	HVBS7MW-94	Vertical Cutting Plate		1
95	HVBS7MW-95	Top Support **		1
96	TS-0813032	Round Head Screw	1/4"x1/2"	4
97	TS-0680021	Flat Washer	1/4"	12
98	HVBS7MW-98	Brush Holder		1
99	TS-0060111	Hex Cap Bolt	3/8"x2-1/2"	2
100	HVBS7MW-100	Brush		1
101	HVBS7MW-101	Nozzle Cock		1
102	TS-0267021	Set Screw	1/4"x1/4"	3
103	HVBS7MW-103	Nozzle Cock Support		1
104	HVBS7MW-104	Valve		1
105	TS-0208071	Hex Socket Cap Screw	5/16"x1-1/4"	2
106	HVBS7MW-106	Adjustable Bracket (left)		1
107	HVBS7MW-107	Adjustable Blade Seat (left)		1
108	HVBS7MW-108	Blade Guard		1
109	HVBS7MW-109	Brush Support		1
110	TS-0050011	Hex Cap Bolt	1/4"x1/2"	7
111	HVBS7MW-111	Guide Plate		2
112	HVBS7MW-112	Set Screw	5/16"x3/4"	1
113	TS-0051071	Hex Cap Bolt	5/16"x1-1/2"	2
114	HVBS7MW-114	Blade Tension Block		1
115	HVBS7MW-115	Sliding Draw Block		1
116	HVBS7MW-116	Switch Cut-Off Bracket		1
117	HVBS7MW-117	Bearing Bushing		1
118	BB-6203Z	Ball Bearing		2
119	HVBS7MW-119	Blade Wheel (left)		1
120	HVBS7MW-120	Blade Tension Handwheel		1
121	HVBS7MW-121	Vertical Cutting Plate		1
122	VB-3V270	V-Belt		1
123	HVBS7MW-123	Worm Pulley		1
124	HVBS7MW-124	Motor Pulley		1
125	HVBS7MW-125	Hex Head Screw	1/4"x3/8"	2
126	HVBS7MW-126	Pulley Cover		1
127	HVBS7MW-127	Lock Screw		1
128	TS-0720071	Lock Washer	1/4"	1
129	HVBS7MW-129	Motor		1
	HVBS7MW-129A	Motor Fan (<i>not shown</i>)		1
	HVBS7MW-129B	Motor Fan Cover (<i>not shown</i>)		1
130	HVBS7MW-130	Motor Mount Plate		1
131	HVBS7MW-131	C-Ring *	S-17	1
132	BB-6003Z	Ball Bearing *		3
134	HVBS7MW-134	Oil Seal *		1
135	HVBS7MW-135	Bearing Bushing *		1
136	HVBS7MW-136	Worm Shaft *		1
137	HVBS7MW-137	Support Plate		1
138	HVBS7MW-138	Motor Support Plate		1
139	HVBS7MW-139	Hex Cap Bolt	1/2"x1-1/4"	1
139A	HVBS7MW-139A	Hex Cap Bolt	1/2"x1-3/16"	1
140	TS-0720111	Lock Washer	1/2"	2
141	HVBS7MW-141	Key	5x20mm	1
142	HVBS7MW-142	Key *	6x20mm	2
143	HVBS7MW-143	Hose Clamp		3
143A	HVBS7MW-143A	Round Head Screw	3/16"x3/8"	3

Index No	Part No	Description	Size	Qty
144	HVBS7MW-144	Bearing Bushing		1
145	HVBS7MW-145	Flat Washer	3/8"	4
146	HVBS7MW-146	Cross Screw	1/8"x1/4"	2
147	HVBS7MW-147	Flat Washer	1/8"	2
148	HVBS7MW-148	Strain Relief Bushing		2
149	HVBS7MW-149	Strain Relief		2
150	HVBS7MW-150	E-Ring	E-7	2
151	HVBS7MW-151	Support Screw		1
152	HVBS7MW-152	Bracket		1
	HVBS7MW-152A	Arm Stop Assembly CP		1
153	HVBS7MW-153	Spring		1
154	HVBS7MW-154	Spring Cap		1
155	HVBS7MW-155	Hex Socket Cap Screw	3/16"x1/2"	1
156	TS-0561031	Nut	3/8"	1
157	TS-0710091	Lock Washer	3/8"	2
158	TS-0060051	Hex Cap Bolt	3/8"x1"	1
159	HVBS7MW-159	Hex Cap Bolt	5/16"x3/4"	1
160	HVBS7MW-160	Hex Cross Head Bolt w/ Lock Washer *	1/4x5/8	4
	HVBS7MW-GB	Gear Box Assembly (<i>not shown</i>)(index #161 thru 163) (S/N: 070935060 and higher)		1
161	TS-0206021	Socket Head Cap Screw*	3/16"x1/2"	3
162	HVBS7MW-162	Block Plate*		1
163	TS-0271032	Socket Set Screw*	3/8"x3/8"	1
164	HVBS7MW-164	Fix bracket		1

* included in HVBS7MW-GB Gear Box Assembly

** included in HVBS7MW-13-RK Cylinder Repair Kit

10.2.1 HVBS-7MW Cylinder Assembly – Exploded View

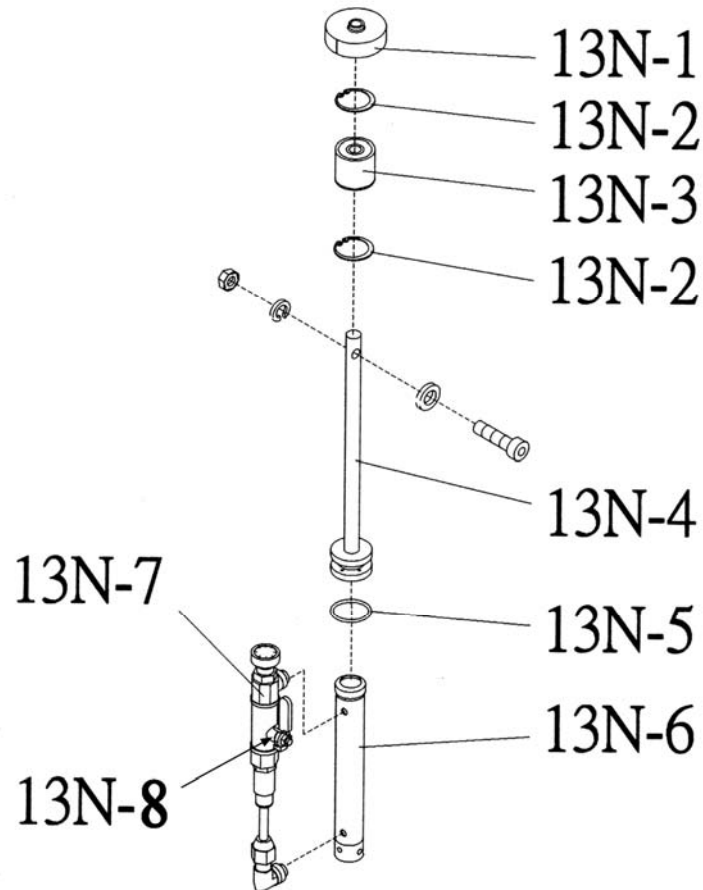

10.2.2 HVBS-7MW Cylinder Assembly – Parts List

Index No	Part No	Description	Size	Qty
13N	HVBS17MW-13N	Cylinder Complete Assembly (S/N: 01028161 and higher)		1
	HVBS17MW-13N-1	Dust Cover		1
	HVBS17MW-13N-2	C-Ring		2
	HVBS17MW-13N-3	Oil Seal		1
	HVBS17MW-13N-4	Oil Piston		1
	HVBS17MW-13N-5	O-Ring		1
	HVBS17MW-13N-6	Cylinder Body		1
	HVBS17MW-13N-7	Oil Pressure Regulator		1
	HVBS17MW-13N-8	Open/Close Valve		1

11.0 Electrical Connections

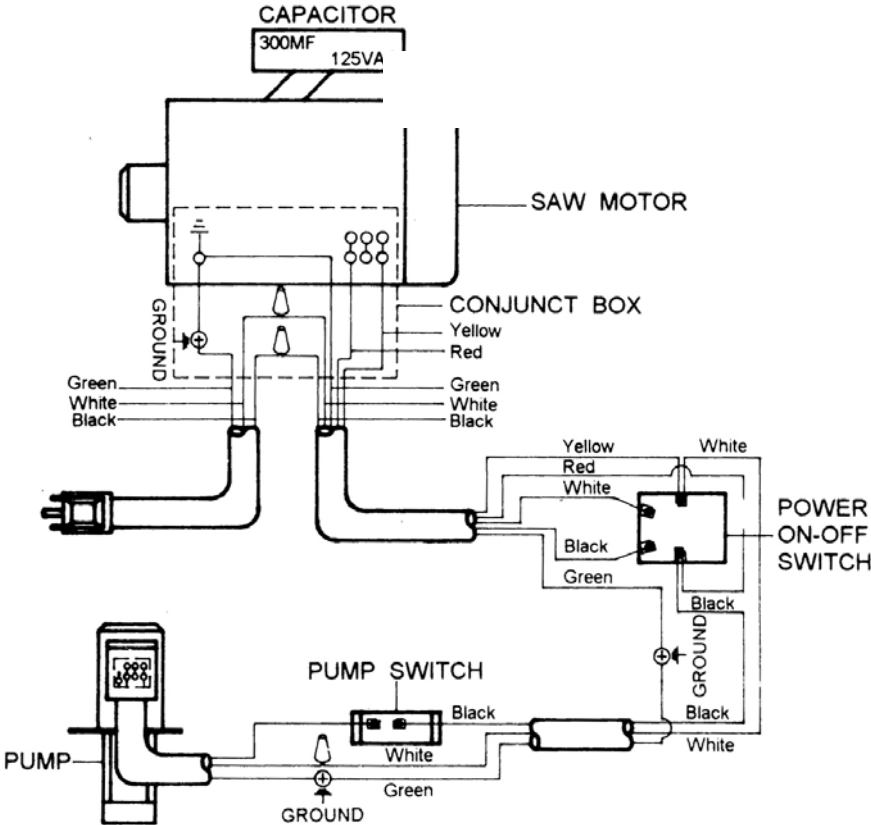

Main Motor Dual Voltage Wiring

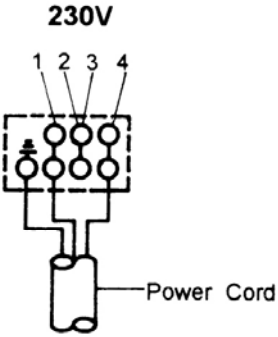
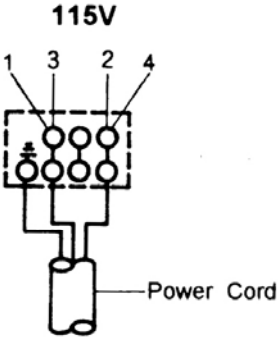

Coolant Pump Dual Voltage Wiring

