

ELECTRIC TOOL PARTS LIST

■ **BAND SAW**
Model CB 75F

1995 · 4 · 10
(E3)

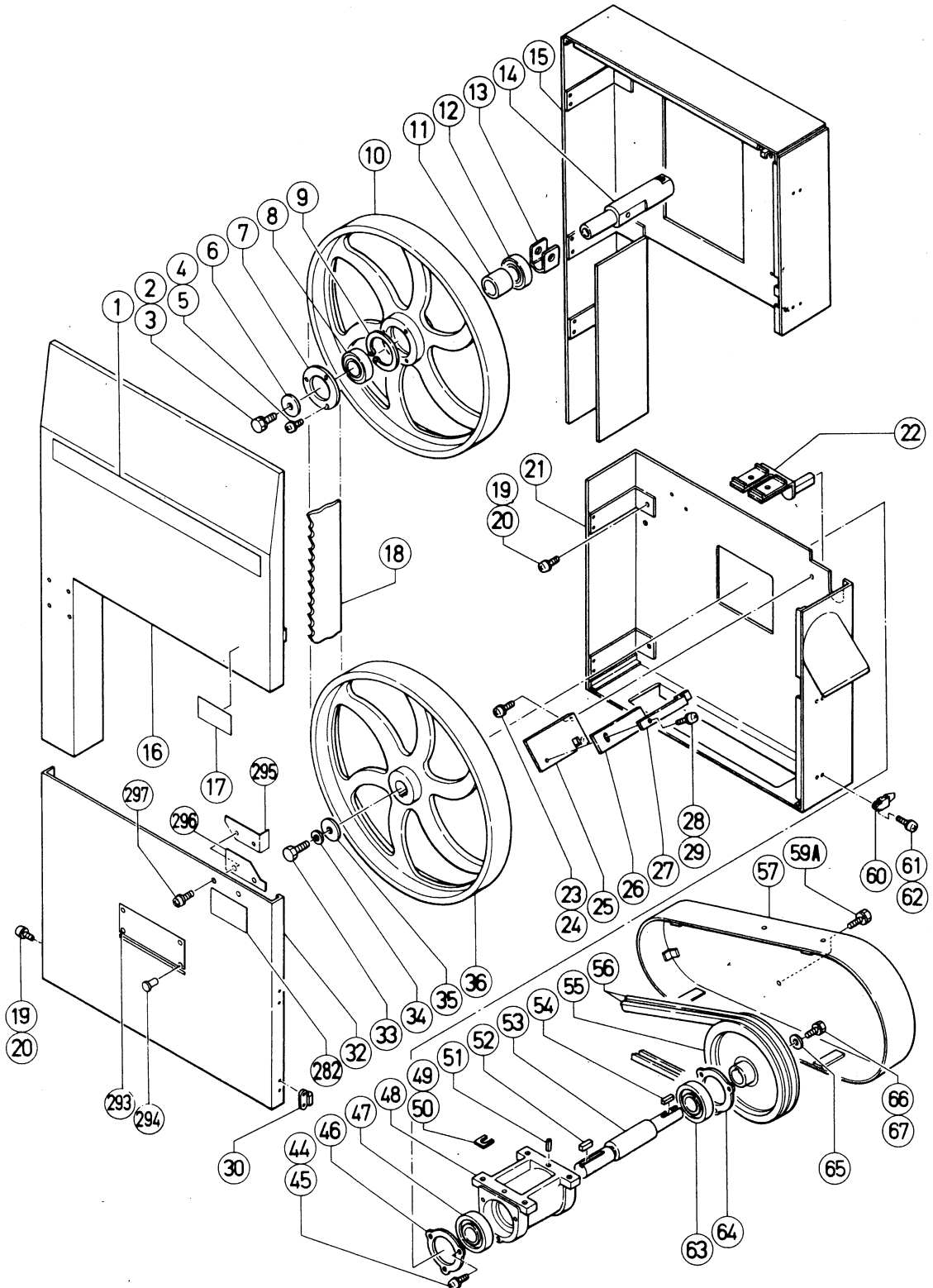

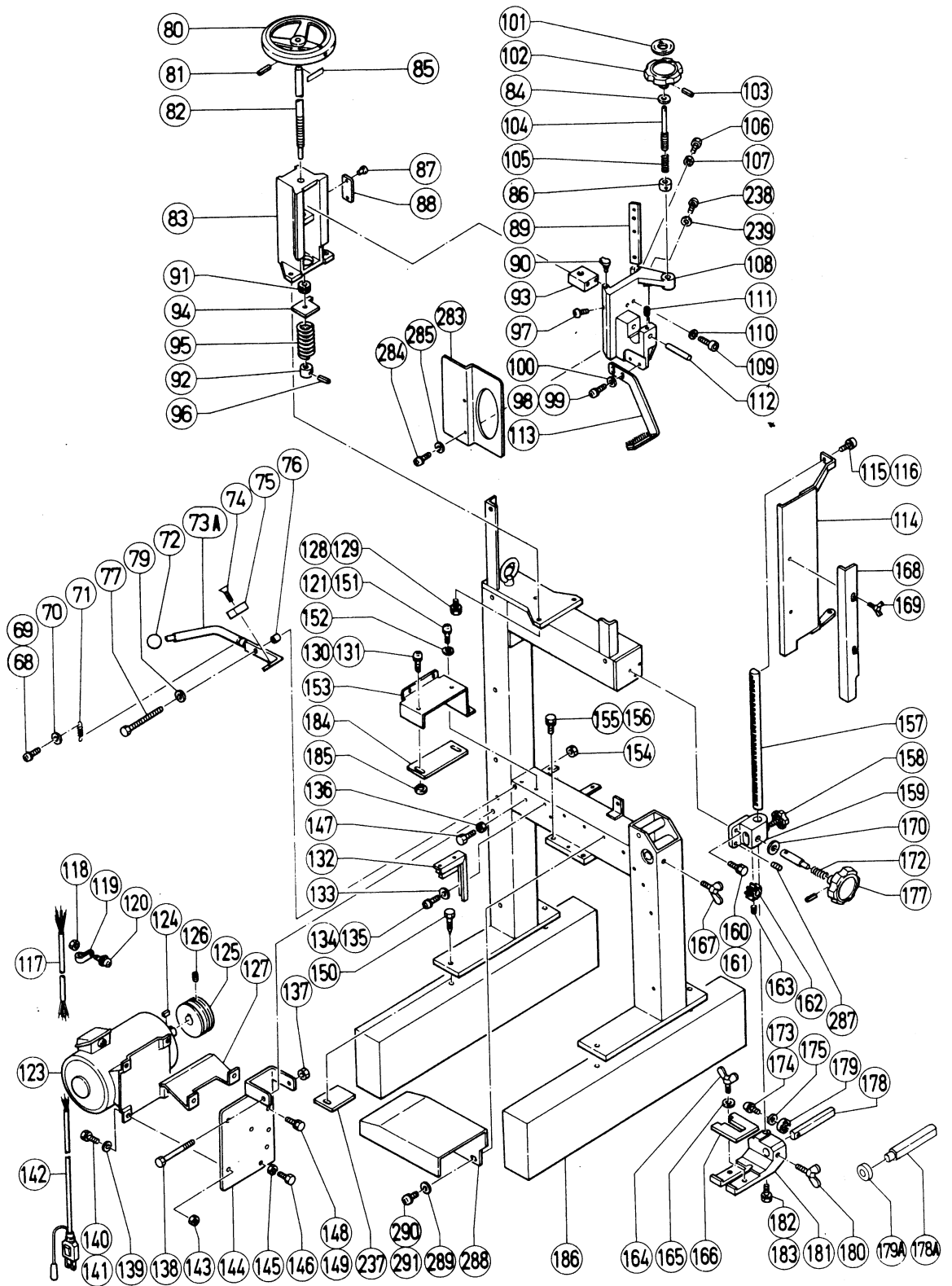

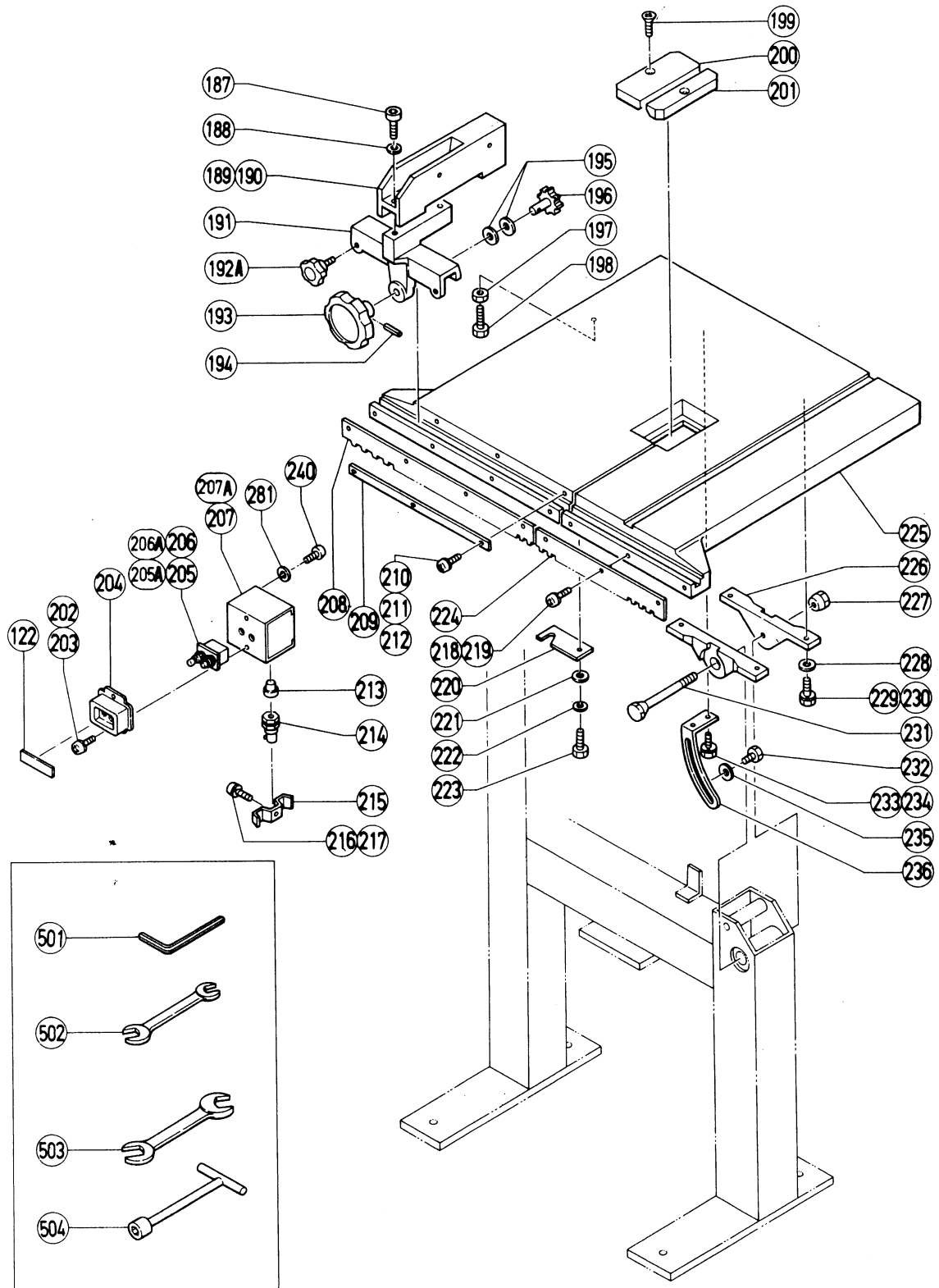

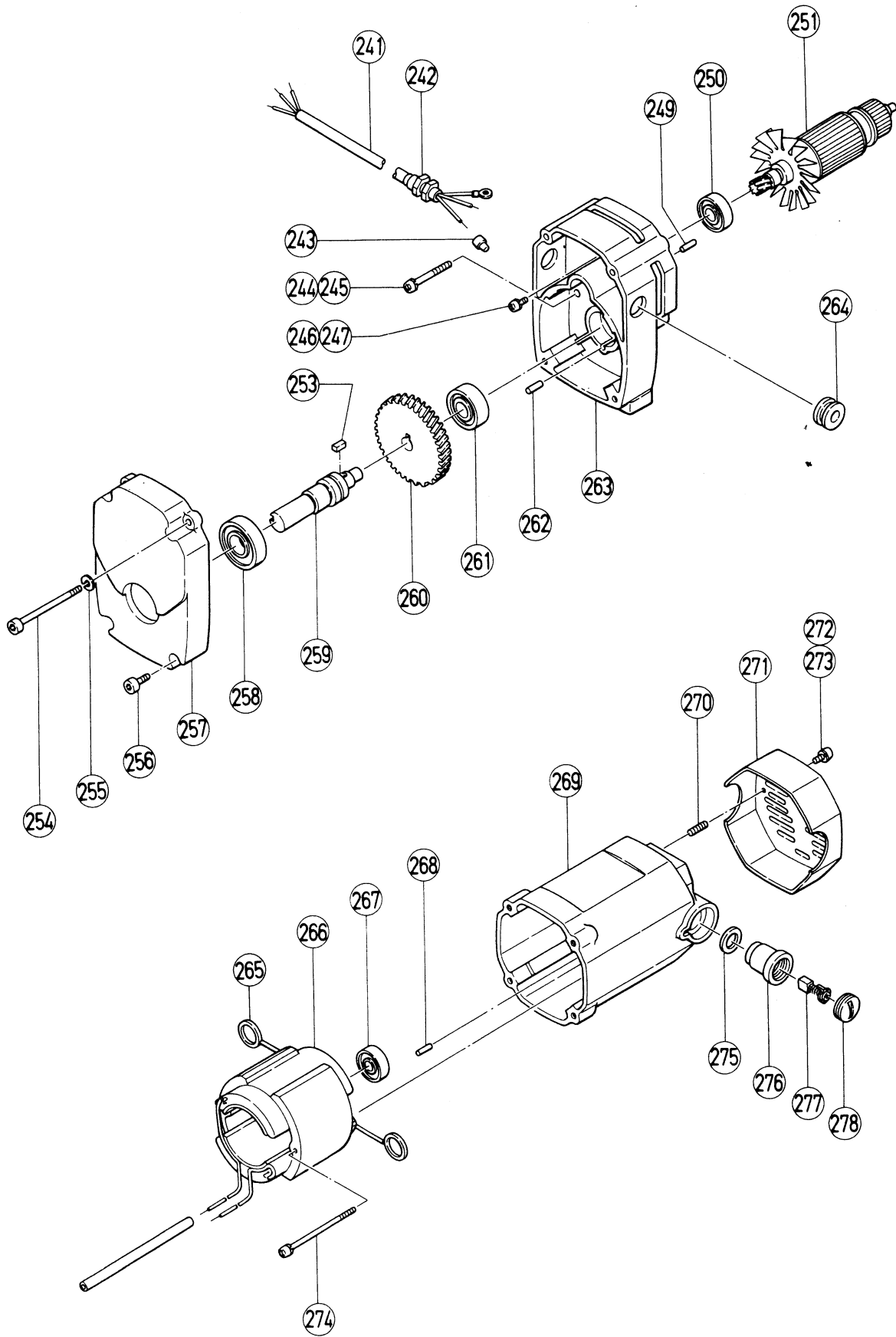

PARTS

CB 75F

ITEM NO.	CODE NO.	DESCRIPTION	NO. USED	REMARKS
1	977-693	HITACHI LABEL	1	
2	949-758	BOLT M12X30 (10 PCS.)	1	
3	949-463	SPRING WASHER M12 (10 PCS.)	1	
4	949-239	MACHINE SCREW M5X16 (10 PCS.)	3	
5	949-454	SPRING WASHER M5 (10 PCS.)	3	
6	967-138	WASHER (S)	1	
7	948-528	BEARING COVER (B)	1	
8	620-6VV	BALL BEARING 6206VVCMP2S	1	
9	977-717	RETAINING RING FOR D62 HOLE	1	
10	977-858	SAW WHEEL (B)	1	
11	967-959	SLEEVE	1	
12	620-6VV	BALL BEARING 6206VVCMP2S	1	
13	967-673	SPACER (C)	1	
14	977-716	SAW SHAFT (B)	1	
15	977-690	UPPER SAW COVER (A)	1	
16	977-691	UPPER SAW COVER (B)	1	
17	977-869	CAUTION PLATE (J)	1	
18	939-971	BAND SAW BLADE (B) (STELLITE TIP)	1	
19	949-236	MACHINE SCREW M5X10 (10 PCS.)	17	
20	949-454	SPRING WASHER M5 (10 PCS.)	17	
21	977-745	LOWER SAW COVER (A)	1	
22	977-744	STABILIZER BASE (A)	1	
23	949-236	MACHINE SCREW M5X10 (10 PCS.)	2	
24	949-454	SPRING WASHER M5 (10 PCS.)	2	
25	977-731	SAW BLADE HOLDER (A)	1	
26	977-733	SAW DUST THROWER	1	
27	977-734	SAW DUST PLATE	1	
28	949-239	MACHINE SCREW M5X16 (10 PCS.)	1	
29	949-454	SPRING WASHER M5 (10 PCS.)	4	
30	975-933	LOCKING LATCH (B)	4	
* 32	977-746	LOWER SAW COVER (B)	1	
* 32	978-103	LOWER SAW COVER (B)	1	FOR USA
33	955-797	SCREW (F)	1	
34	949-463	SPRING WASHER M12 (10 PCS.)	1	
35	967-138	WASHER (S)	1	
36	977-700	SAW WHEEL (A)	1	
44	949-239	MACHINE SCREW M5X16 (10 PCS.)	6	
45	949-454	SPRING WASHER M5 (10 PCS.)	6	
46	948-506	BEARING COVER (A)	1	
47	630-6VV	BALL BEARING 6306VVCMP2S	1	
48	977-697	CASING (A)	1	
49	966-511	LINER (A) T0.1	2	
50	966-512	LINER (A) T0.2	2	
51	949-753	ROLL PIN D5X20 (10 PCS.)	2	
52	967-174	FEATHER KEY 7X7X30	1	
53	977-698	SAW SHAFT (A)	1	
54	967-174	FEATHER KEY 7X7X30	1	
55	967-972	PULLEY (C)	1	
* 56	977-878	V - BELT (A - 41)	2	FOR SINGLE - PHASE
* 56	977-879	V - BELT (A - 43)	2	FOR THREE - PHASE
* 57	977-752	BELT COVER	1	FOR SINGLE - PHASE

*: ALTERNATIVE PARTS

PARTS

ITEM NO.	CODE NO.	DESCRIPTION	NO. USED	REMARKS
57	977-707	BELT COVER	1	FOR THREE - PHASE
58A	988-495	BOLT (W/WASHERS) M8X16	3	
60	977-692	LOCKING LATCH (A)	4	
61	949-204	MACHINE SCREW M3X10 (10 PCS.)	16	
62	949-451	SPRING WASHER M3 (10 PCS.)	16	
63	630-5VV	BALL BEARING 6305VVCMP2S	1	
64	948-528	BEARING COVER (B)	1	
65	974-608	SPECIAL WASHER M12	1	
66	949-758	BOLT M12X30 (10 PCS.)	1	
67	949-463	SPRING WASHER M12 (10 PCS.)	1	
68	949-239	MACHINE SCREW M5X16 (10 PCS.)	1	
69	949-454	SPRING WASHER M5 (10 PCS.)	1	
70	949-431	BOLT WASHER M5 (10 PCS.)	1	949432 M6 1/20/98
71	977-877	BRAKE SPRING	1	
72	968-636	GRIP (B) <i>from Mfg # 090999</i>	1	932344 from Mfg # N76601
73A	977-855	BRAKE HANDLE	1	318658
74	949-331	FLAT HD. SCREW M5X10 (10 PCS.)	1	
75	977-737	LINING	1	
76	977-856	SPACER	1	
77	973-587	HIGH TENSION BOLT M8X100	1	
79	949-433	BOLT WASHER M8 (10 PCS.)	2	
80	977-713	ROUND HANDLE 160MM	1	
81	949-681	ROLL PIN D5X25 (10 PCS.)	1	
82	977-711	FEED SCREW	1	
83	977-710	SLIDE FRAME	1	
84	949-437	BOLT WASHER M12 (10 PCS.)	1	
85	968-331	MARK PLATE (B)	1	
86	977-861	SLEEVE (A)	1	
87	949-510	RIVET D2.5X4.8 (10 PCS.)	2	
88	977-871	SCALE	1	
89	977-860	LINER	1	
90	973-681	CUP	2	
91	977-712	THRUST BEARING (51100)	1	
92	977-715	SPRING GUIDE	1	
93	977-718	FEMALE SCREW	1	
94	977-714	GAUGE	1	
95	967-665	TENSION SPRING	1	
96	949-753	ROLL PIN D5X20 (10 PCS.)	1	
97	949-256	MACHINE SCREW M6X16 (10 PCS.)	1	
98	949-239	MACHINE SCREW M5X16 (10 PCS.)	2	
99	949-454	SPRING WASHER M5 (10 PCS.)	2	
100	949-431	BOLT WASHER M5 (10 PCS.)	2	
101	977-870	KNOB MARK	1	
102	977-721	KNOB	1	
103	949-548	ROLL PIN D4X25 (10 PCS.)	2	
104	977-719	KNOB SHAFT	1	
105	977-720	SPRING (A)	1	
106	968-959	SPECIAL BOLT M6	3	
107	949-556	NUT M6 (10 PCS.)	4	
108	977-753	SLIDER	1	
* 108	977-708	SLIDER	1	FOR USA,CAN

*: ALTERNATIVE PARTS

PARTS

CB 75F

ITEM NO.	CODE NO.	DESCRIPTION	NO. USED	REMARKS
109	949-760	HEX. SOCKET HD. BOLT M8X25 (10 PCS.)	2	
110	949-457	SPRING WASHER M8 (10 PCS.)	2	
111	966-292	HEX. SOCKET SET SCREW M5X12	1	
112	967-671	PIN	1	
113	977-740	DUSTER (B)	1	
114	977-727	SAFETY COVER	1	
115	949-256	MACHINE SCREW M6X16 (10 PCS.)	1	
118	949-455	SPRING WASHER M8 (10 PCS.)	1	
*	117	977-867	CORD	1 FOR THREE - PHASE
*	118	949-554	NUT M4 (10 PCS.)	1 FOR THREE - PHASE
*	119	967-579	NYLON CLIP	1 FOR THREE - PHASE
*	120	986-662	MACHINE SCREW (W/WASHERS) M4X10	1 FOR THREE - PHASE
	121	949-236	MACHINE SCREW M5X10 (10 PCS.)	4
*	122	932-161	SWITCH NAME PLATE (E)	1 (TILL 10.1990 FOR USA)
*	123		MOTOR	1
	124	975-559	FEATHER KEY 8X7X38	1
	125	977-696	PULLEY (A)	1
	126	967-469	HEX. SOCKET SET SCREW M6X6	1
*	127	967-691	MOTOR COVER (THREE - PHASE)	1
	128	949-698	BOLT M10X30 (10 PCS.)	3
	129	949-458	SPRING WASHER M10 (10 PCS.)	3
	130	949-236	MACHINE SCREW M5X10 (10 PCS.)	2
	131	949-454	SPRING WASHER M5 (10 PCS.)	2
	132	977-735	DUSTER (A)	1
	133	949-431	BOLT WASHER M5 (10 PCS.)	2
	134	949-239	MACHINE SCREW M5X16 (10 PCS.)	2
	135	949-454	SPRING WASHER M5 (10 PCS.)	2
	136	949-555	NUT M5 (10 PCS.)	1
	137	949-572	LOCK NUT M10 (10 PCS.)	2
	138	977-695	BOLT M10X100	1
*	139	949-433	BOLT WASHER M8 (10 PCS.)	4 FOR THREE - PHASE
*	140	949-626	BOLT M8X25 (10 PCS.)	4 FOR THREE - PHASE
*	141	949-457	SPRING WASHER M8 (10 PCS.)	4 FOR THREE - PHASE
*	142	977-777	CORD (FOR SINGLE - PHASE)	1
*	142	977-866	CORD (FOR THREE - PHASE)	1
*	142	977-778	CORD (FOR SINGLE - PHASE)	1 FOR USA(UL),USA
*	142	977-779	CORD (FOR SINGLE - PHASE)	1 FOR ARG
*	142	977-780	CORD (FOR SINGLE - PHASE)	1 FOR THREE PIN PLUG
*	142	977-781	CORD (FOR SINGLE - PHASE)	1 FOR SIN
*	142	977-782	CORD (FOR SINGLE - PHASE)	1 FOR NZL
*	143	949-558	NUT M8 (10 PCS.)	4 FOR THREE - PHASE
	144	977-694	MOTOR BASE	1
	145	949-572	LOCK NUT M10 (10 PCS.)	1
	146	974-638	BOLT M10X60	1
	147	949-664	HEX. SOCKET HD. BOLT M5X30 (10 PCS.)	1
*	148	949-624	BOLT M8X20 (10 PCS.)	3 FOR SINGLE - PHASE
*	149	949-457	SPRING WASHER M8 (10 PCS.)	3 FOR SINGLE - PHASE
	150	973-854	SPECIAL SCREW W3/8X75	4
	151	949-454	SPRING WASHER M5 (10 PCS.)	4
	152	949-431	BOLT WASHER M5 (10 PCS.)	2
	153	977-851	LOWER SAW COVER (C)	1

*: ALTERNATIVE PARTS

PARTS

CB 75F

ITEM NO.	CODE NO.	DESCRIPTION	NO. USED	REMARKS
154	949-568	LOCK NUT M8 (10 PCS.)	1	
155	949-628	BOLT M8X30 (10 PCS.)	4	
156	949-457	SPRING WASHER M8 (10 PCS.)	4	
157	977-723	STABILIZER SHAFT	1	
158	977-875	KNOB BOLT 8X30	1	
159	977-722	ARM	1	
160	949-626	BOLT M8X25 (10 PCS.)	3	
161	949-457	SPRING WASHER M8 (10 PCS.)	3	
162	977-724	PINION	1	
163	952-384	HEX. SOCKET SET SCREW M5X10	1	
164	949-402	WING BOLT M6X15 (10 PCS.)	2	
165	967-329	WASHER (H)	4	
166	977-729	STABILIZER	4	
167	949-413	WING BOLT M8X25 (10 PCS.)	1	
168	948-844	SAFETY COVER (B)	1	
169	949-395	WING BOLT M5X6 (10 PCS.)	2	
170	949-438	BOLT WASHER M16 (10 PCS.)	1	
172	977-853	SPRING (B)	1	
173	949-846	HEX. SOCKET HD. BOLT M10X30 (10 PCS.)	1	TILL 3.1990
174	949-458	SPRING WASHER M10 (10 PCS.)	1	TILL 3.1990
175	949-434	BOLT WASHER M10 (10 PCS.)	2	TILL 3.1990
177	978-100	KNOB	1	
178A	978-106	BEARING SHAFT ASS'Y	1	INCLUD.179A
179	620-0VV	BALL BEARING 6200VVCMP2S	1	TILL 3.1990
179A	630-0VV	BALL BEARING 6300VVCMAV2S	1	SINCE 4.1990
180	949-689	WING BOLT M8X30 (10 PCS.)	1	
181	977-728	STABILIZER BASE (B)	1	
182	949-679	BOLT M10X50 (10 PCS.)	1	
183	949-458	SPRING WASHER M10 (10 PCS.)	1	
184	977-733	SAW DUST THROWER	1	
185	973-237	TABLE HOLDER	2	
186		WOODEN STAND	2	
187	949-846	HEX. SOCKET HD. BOLT M10X30 (10 PCS.)	2	
188	949-458	SPRING WASHER M10 (10 PCS.)	2	
189	977-758	GUIDE ASS'Y	1	INCLUD.187,188,190,191
190	977-876	GUIDE	1	
191	968-339	GUIDE HOLDER	1	
192A	978-905	KNOB BOLT M10X30	2	
193	974-771	KNOB	1	
194	949-681	ROLL PIN D5X25 (10 PCS.)	1	
195	949-437	BOLT WASHER M12 (10 PCS.)	3	
196	967-953	PINION	1	
197	949-572	LOCK NUT M10 (10 PCS.)	1	
198	949-634	BOLT M10X60 (10 PCS.)	1	
199	949-793	FLAT HD. SCREW M5X20 (10 PCS.)	2	
200	977-706	TABLE INSERT (B)	1	
201	977-852	TABLE INSERT (A)	1	
* 202	949-236	MACHINE SCREW M5X10 (10 PCS.)	2	(TILL 10.1990 FOR USA)
* 203	949-454	SPRING WASHER M5 (10 PCS.)	2	(TILL 10.1990 FOR USA)
* 204	965-580	SWITCH PROTECTOR (B)	1	(TILL 10.1990 FOR USA)
* 205	947-100	SWITCH (2P SOLDER TYPE)	1	(TILL 10.1990 FOR USA)

*: ALTERNATIVE PARTS

PARTS

CB 75F

ITEM NO.	CODE NO.	DESCRIPTION	NO. USED	REMARKS
* 205A	972-082Z	SWITCH (1P SOLDER TYPE)	1	SINCE 11.1990 FOR USA
* 206	937-297	SWITCH INSULATOR	1	(TILL 10.1990 FOR USA)
* 206A	971-939Z	RUBBER PLATE	1	SINCE 11.1990 FOR USA
* 207	977-857	SWITCH COVER (A)	1	(TILL 10.1990 FOR USA)
* 207A	978-109	SWITCH COVER (B)	1	SINCE 11.1990 FOR USA
208	948-830	RACK	1	
209	967-976	SCALE (B)	1	
210	949-216	MACHINE SCREW M4X10 (10 PCS.)	3	
211	949-453	SPRING WASHER M4 (10 PCS.)	3	
212	949-429	BOLT WASHER M4 (10 PCS.)	3	
* 213	959-141	CONNECTOR 50092 (10 PCS.)	2	FOR SINGLE – PHASE
* 213	959-141	CONNECTOR 50092 (10 PCS.)	1	FOR THREE – PHASE
214	974-285	CORD LOCK (NC – 1)	2	
215	965-378	CORD CLIP	2	
216	949-256	MACHINE SCREW M6X16 (10 PCS.)	1	
217	949-455	SPRING WASHER M6 (10 PCS.)	2	
218	949-236	MACHINE SCREW M5X10 (10 PCS.)	7	
219	949-454	SPRING WASHER M5 (10 PCS.)	7	
220	974-244	TABLE PIECE	1	
221	949-433	BOLT WASHER M8 (10 PCS.)	2	
222	949-457	SPRING WASHER M8 (10 PCS.)	2	
223	967-594	HIGH TENSION BOLT M8X25	2	
224	948-831	RACK	1	
225	977-701	TABLE	1	
226	977-850	HINGE	2	
227	977-704	TABLE NUT	1	
228	949-433	BOLT WASHER M8 (10 PCS.)	4	
229	949-628	BOLT M8X30 (10 PCS.)	4	
230	949-457	SPRING WASHER M8 (10 PCS.)	4	
231	977-703	TABLE SHAFT	1	
232	934-368	HIGH TENSION BOLT M8X16	1	
233	949-624	BOLT M8X20 (10 PCS.)	2	
234	949-457	SPRING WASHER M8 (10 PCS.)	2	
235	948-541	WASHER (D)	1	
236	977-705	TILT PLATE	1	
237	977-751	RUBBER WASHER	4	
238	949-253	MACHINE SCREW M6X8 (10 PCS.)	1	
239	949-455	SPRING WASHER M6 (10 PCS.)	1	
240	949-216	MACHINE SCREW M4X10 (10 PCS.)	4	

*: ALTERNATIVE PARTS

PARTS

MOTOR

CB 75F

ITEM NO.	CODE NO.	DESCRIPTION	NO. USED	REMARKS
241	977-883	CORD (A)	1	
242	974-285	CORD LOCK (NC - 1)	1	
243	959-141	CONNECTOR 50092 (10 PCS.)	2	
244	949-284	MACHINE SCREW M6X40 (10 PCS.)	2	
245	949-455	SPRING WASHER M6 (10 PCS.)	2	
246	949-214	MACHINE SCREW M4X6 (10 PCS.)	1	
247	949-453	SPRING WASHER M4 (10 PCS.)	1	
249	976-441	BEARING LOCK	1	
250	620-2VV	BALL BEARING 6202VVCMP2S	1	
* 251	974-727E	ARMATURE 220V - 240V	1	FOR SINGLE - PHASE
* 251A	974-727U	ARMATURE ASS'Y 110V - 127V	1	FOR SINGLE - PHASE INCLUD.250,267
253	930-511	FEATHER KEY 4X4X10	1	
254	949-835	HEX. SOCKET HD. BOLT M6X85 (10 PCS.)	2	
255	949-455	SPRING WASHER M6 (10 PCS.)	4	
256	949-852	HEX. SOCKET HD. BOLT M6X25 (10 PCS.)	2	
257	974-723	COVER	1	
258	620-5VV	BALL BEARING 6205VVCMP2S	1	
259	974-729	SPINDLE	1	
260	974-722	GEAR	1	
261	620-2VV	BALL BEARING 6202VVCMP2S	1	
262	976-441	BEARING LOCK	2	
263	977-882	GEAR COVER	1	
264	973-420	CORD ARMOR (B) D12.0	1	
265	998-744	BRUSH TERMINAL	2	
* 266	968-914C	STATOR ASS'Y 110V - 115V	1	FOR SINGLE - PHASE INCLUD.265
* 266	968-914E	STATOR ASS'Y 220V - 230V	1	FOR SINGLE - PHASE INCLUD.265
* 266	968-914F	STATOR ASS'Y 240V	1	FOR SINGLE - PHASE INCLUD.265
267	620-0VV	BALL BEARING 6200VVCMP2S	1	
268	976-441	BEARING LOCK	1	
269	951-240	HOUSING ASS'Y	1	INCLUD.270,278
270	952-384	HEX. SOCKET SET SCREW M5X10	2	
271	951-244	TAIL COVER	1	
272	949-236	MACHINE SCREW M5X10 (10 PCS.)	2	
273	949-454	SPRING WASHER M5 (10 PCS.)	2	
274	977-749	MACHINE SCREW (W/SP. WASHER) M5X80	2	
275	976-307	STOP PLATE	2	
276	978-441	BRUSH HOLDER	2	
277	999-044	CARBON BRUSH (1 PAIR)	2	
278	978-445	BRUSH CAP	2	
281	949-453	SPRING WASHER M4 (10 PCS.)	4	
282	977-775	CAUTION PLATE (A)	1	
283	977-776	UPPER SAW COVER (C)	1	
284	949-236	MACHINE SCREW M5X10 (10 PCS.)	2	
285	949-454	SPRING WASHER M5 (10 PCS.)	2	
287	967-237	HEX. SOCKET SET SCREW M8X12	2	
288	977-791	LOWER SAW WHEEL COVER	1	
289	967-329	WASHER (H)	3	
290	949-236	MACHINE SCREW M5X10 (10 PCS.)	3	
291	949-454	SPRING WASHER M5 (10 PCS.)	3	
292	949-613	BOLT M6X16 (10 PCS.)	2	
293		NAME PLATE	1	

*: ALTERNATIVE PARTS

4 - 95

STANDARD ACCESSORIES

CB 75F

ITEM NO.	CODE NO.	DESCRIPTION	NO. USED	REMARKS	
501	955-857	HEX. BAR WRENCH 8MM	1		
502	972-043	WRENCH 10/13MM	1		
503	974-254	WRENCH 17/19MM	1		
504	966-821	BOX WRENCH 13MM	1		

OPTIONAL ACCESSORIES

ITEM NO.	CODE NO.	DESCRIPTION	NO. USED	REMARKS	
601	967-684	GUIDE (B) ASS'Y <i>Spring Guide</i>	1	<i>pg 14 owners manual</i>	
602	948-583	MITER GAUGE	1		
603	967-701	BAND SAW BLADE (A) (STELLITE TIP)	1		
604	967-703	BAND SAW BLADE (B)	1		
605	967-712	BAND SAW BLADE (C) 25MM	1		
606	967-990	BAND SAW BLADE (E) 12.5MM	1		
607	967-991	BAND SAW BLADE (F) 9.25MM	1		
608	967-992	BAND SAW BLADE (G) 6MM	1		
609	977-872	SUB ROLLER	1		
610	977-873	BAND SAW BLADE GUIDE ASS'Y 25MM	1		
611	977-874	BAND SAW BLADE GUIDE ASS'Y 12.5MM	1		

*: ALTERNATIVE PARTS