



**SERVICE PARTS LIST**  
PAGE 1 OF 6 BASE ASSEMBLY

**BULLETIN NO.**  
**54-40-6925**

SPECIFY CATALOG NO. AND SERIAL NO. WHEN ORDERING PARTS		REVISED BULLETIN	DATE
<b>12" SLIDING COMPOUND MITER SAW</b>			Apr. 2011
CATALOG NO.	<b>6955-20</b>	SERIAL NUMBER	<b>B26A</b>
		WIRING INSTRUCTION <b>58-01-6925</b>	

**EXAMPLE:**  
00 0 Component Parts (Small #) Are Included  
When Ordering The Assembly (Large #).

FIG.	PART NO.	DESCRIPTION OF PART	NO REQ.
1	02-80-0050	Thrust Bearing	(1)
2	05-80-0510	M5 x 12mm Flat Head T-20 Screw	(5)
3	05-81-0135	M5 x 13mm Pan Head T-25 Screw	(8)
4	05-81-0150	M8 x 25mm Pan Head T-45 Screw	(4)
5	05-81-0235	M5 x 7mm Pan Head T-25 Screw	(2)
6	05-86-0640	M5 x 18mm Hex Socket Set Screw	(1)
7	05-86-0660	M12 x 1 x 18mm T-25 Socket Set Screw	(2)
8	05-89-0530	M5 x 13mm Pan Hd T-25 Shoulder Scr	(5)
9	10-20-9115	Fence Label	(2)
10	22-38-0175	Cable Clamp	(1)
11	23-45-0010	Potentiometer (Incl. Hex Nut & Star Washer)	(1)
12	28-06-1260	12" Sliding Miter Base	(1)
13	28-35-0105	Fixed Fence	(1)
14	28-35-0110	Left Fence (Moving Fence)	(1)
15	28-35-0120	Right Fence	(1)
16	32-48-0121	Rack	(1)
17	40-50-8620	Belleville Spring	(4)
18	42-70-5145	Wrench Clamp	(1)
19	42-92-1130	Potentiometer Cover	(1)
20	43-82-0165	Miter Scale	(1)
21	43-98-0275	Lock Knob Bolt	(2)
22	44-34-0025	Miter Base Foot	(4)
23	44-52-0950	Handle Grip	(2)
24	44-66-0970	Potentiometer Plate	(1)
25	45-96-0300	Blade Wrench	(1)
60	42-90-0130	Tolerance Ring	(1)
76	45-08-0455	Table Bolt	(1)

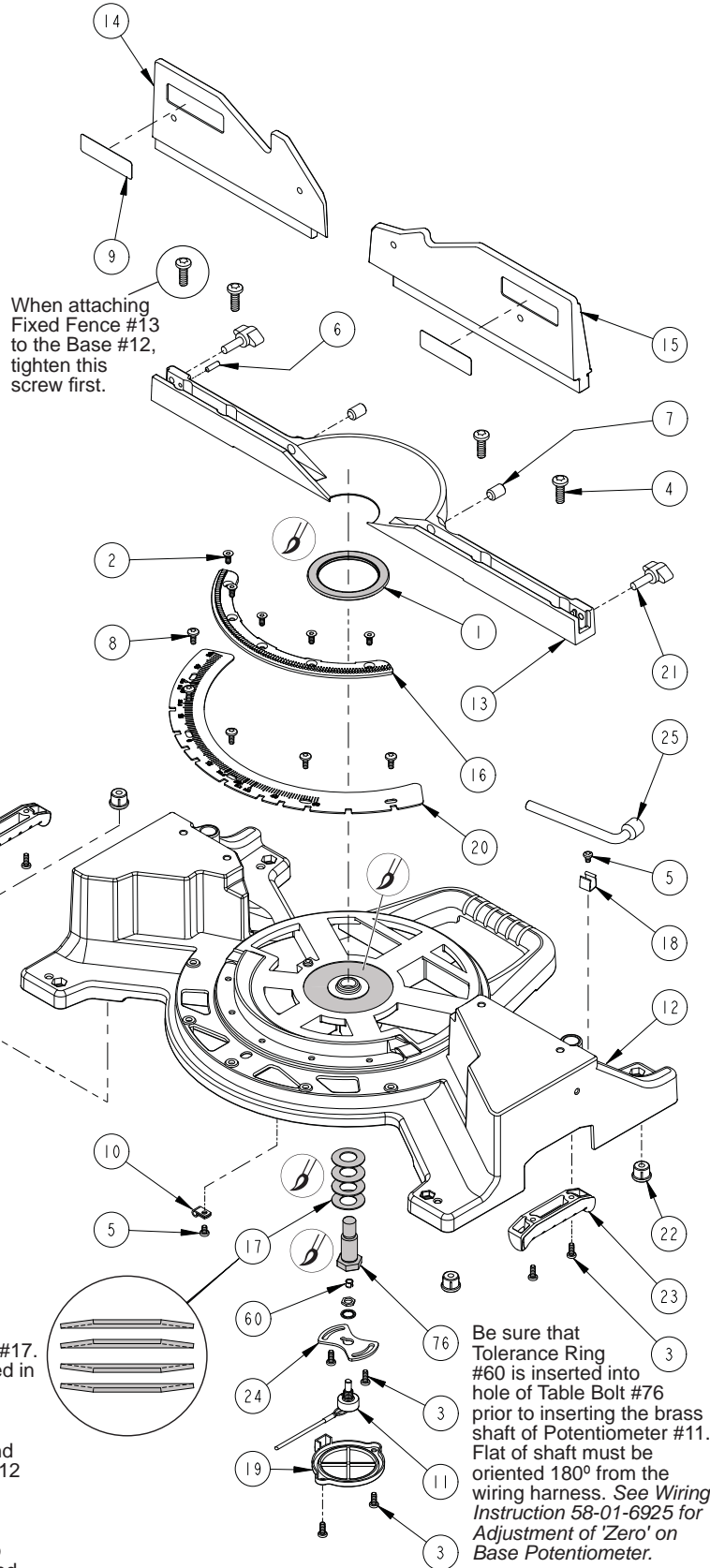

**SERVICE NOTES:**

Orient Thrust Bearing #1 with printed ID stripe up, facing away from Base #12.

When assembling the Fixed Fence #13 to the Base #12, secure the left most Screw #4 as illustrated, followed by the other three screws.

**Moving Fence Adjustment: (Left Fence)**

- Turn Set Screw #7 (located on left side of Fixed Fence #13) clockwise until Set Screw touches Moving Fence #14, then back off 1/8 to 1/4 turn.
- The Moving Fence #14 must be able to be rotated and slide past the Set Screw #6.
- Set Screw #6 must protrude past machined surface of Fixed Fence #13.

**Removable Fence Adjustment: (Right Fence)**

- Turn Set Screw #7 (located on right side of Fixed Fence #13) clockwise until Set Screw touches Removable Fence #15, then back off 1/8 to 1/4 turn.



**LUBRICATION NOTE**

Place a light coat of Type 'Y' grease, No. 49-08-5270 to Belleville Springs #17. Belleville Springs are to be assembled in the order shown.

Place a light coat of Type 'Y' grease, to both sides of Thrust Bearing #1 and corresponding center bore of Base #12 as shown.

Place a light coat of Type 'Y' grease, on the shaft of Table Bolt #76 prior to inserting through hole in Base #12 and threading into hole on the bottom of Table #43 (shown on next page).

Be sure that Tolerance Ring #60 is inserted into hole of Table Bolt #76 prior to inserting the brass shaft of Potentiometer #11. Flat of shaft must be oriented 180° from the wiring harness. See Wiring Instruction 58-01-6925 for Adjustment of 'Zero' on Base Potentiometer.



**SERVICE PARTS LIST**  
PAGE 2 OF 6 TABLE ASSEMBLY

**BULLETIN NO.**  
**54-40-6925**

SPECIFY CATALOG NO. AND SERIAL NO. WHEN ORDERING PARTS			REVISED BULLETIN	DATE
<b>12" SLIDING COMPOUND MITER SAW</b>				Apr. 2011
<b>CATALOG NO.</b>	<b>6955-20</b>	<b>SERIAL NUMBER</b>	<b>WIRING INSTRUCTION</b> <b>58-01-6925</b>	
		<b>B26A</b>		

**EXAMPLE:**  
00 0

Component Parts (Small #) Are Included  
When Ordering The Assembly (Large #).

\* Early designs of Switch Mount #44 had individual spacers. Service replacement has spacers molded into part.

FIG.	PART NO.	DESCRIPTION OF PART	NO REQ.
27	05-55-0915	M8 Prevailing Torque Nut	(1)
28	05-81-0115	M4 x 6mm Pan Head T-20 Screw	(1)
29	05-81-0130	M4 x 8mm Pan Head T-20 Screw	(5)
30	05-81-0135	M5 x 13mm Pan Head T-25 Screw	(20)
31	05-81-0200	M5 x 10mm Pan Head T-25 Screw	(2)
32	05-81-0235	M5 x 7mm Pan Head T-25 Screw	(1)
33	05-86-0640	M5 x 18mm Set Screw	(1)
34	05-88-5910	M3.5 x 8mm Pan Hd Slit T-10 PT Screw	(4)
35	05-88-5988	K50 x 35mm Slit Pan Hd T-20 Screw	(2)
36	10-20-7900	Fine Adjustment Label	(1)
37	10-20-9120	Slide Label	(1)
38	10-20-9125	Fine Adjustment Warning Label	(1)
39	10-20-9135	Round Label	(2)
40	22-09-1580	LCD Assembly	(1)
41	22-38-0175	Cable Clamp	(4)
42	23-66-0705	Digital Readout Calibration Switch	(1)
44	31-01-1575	Switch Mount (Miter)	(1)
45	31-12-0030	Bearing Cap	(1)
46	32-48-0115	Fine Adjustment Tube Gear	(1)
47	-----	Fine Adjustment Gear	(1)
48	32-48-0130	Reduction Gear	(1)
49	-----	Pinion Gear	(1)
50	34-60-0020	External Retaining Ring	(2)
51	-----	External Retaining Ring	(1)
52	34-60-1450	E-Ring	(1)
53	40-50-0390	Spring	(1)
54	40-50-0455	Miter Detent Spring	(1)
55	40-50-0460	Fine Adjustment Return Spring	(1)
56	-----	Slide Block	(1)
57	-----	Fine Adjustment Chassis	(1)
58	-----	Lock Handle Cap	(1)
59	42-52-1040	Spring Cap	(2)
60	42-90-0130	Tolerance Ring	(1)
61	42-92-1135	Cover (Detent Mech.)	(1)
62	43-62-1340	Detent Lever Handle	(1)

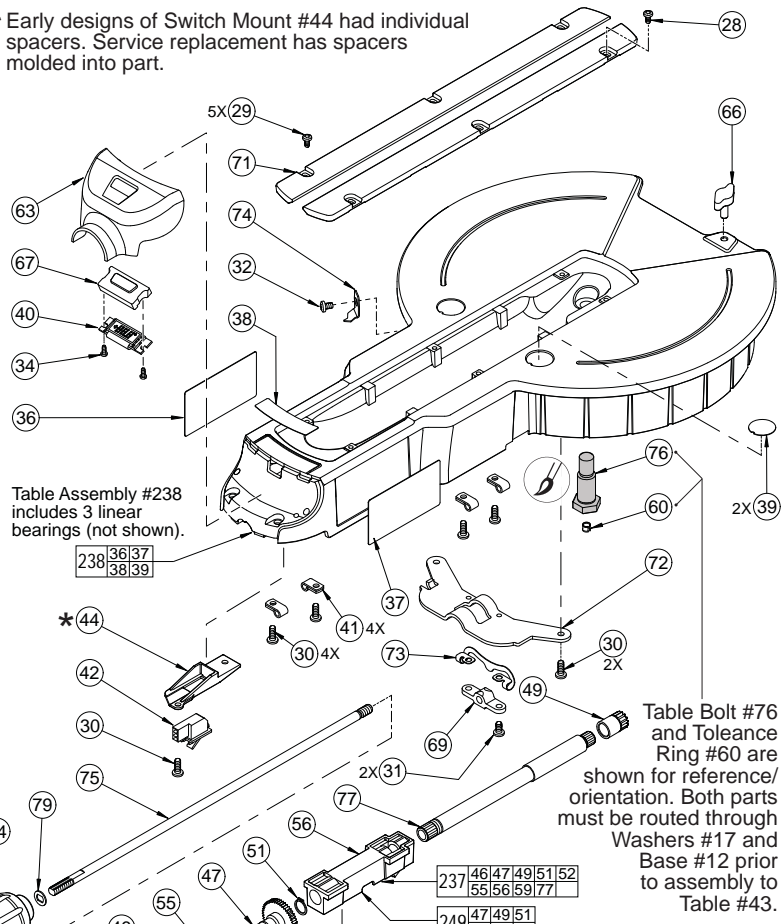
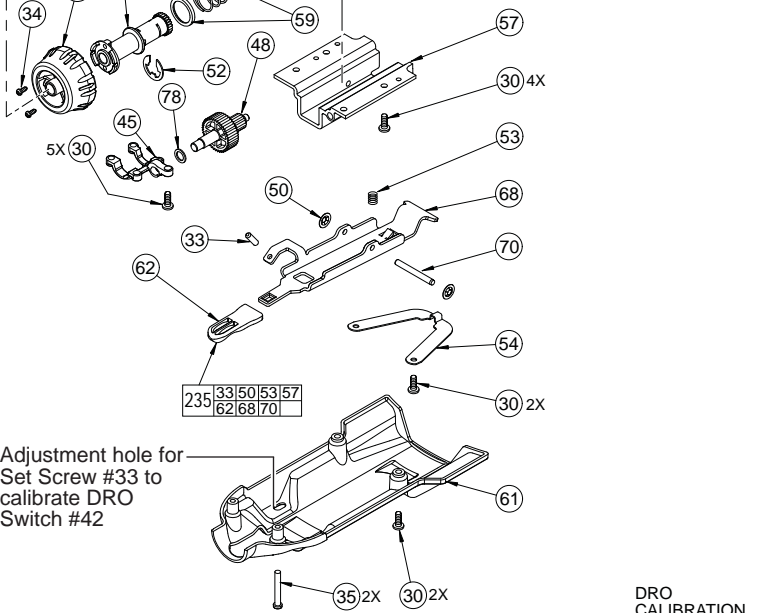

Table Assembly #238 includes 3 linear bearings (not shown).

Table Bolt #76 and Tolerance Ring #60 are shown for reference/orientation. Both parts must be routed through Washers #17 and Base #12 prior to assembly to Table #43.

**LUBRICATION NOTES**  
Place a light coat of Type 'Y' grease, No. 49-08-5270 to Table Bolt #76.

FIG.	PART NO.	DESCRIPTION OF PART	NO REQ.
63	43-76-0740	LCD Cover	(1)
64	-----	Table Lock Knob	(1)
65	43-98-0250	Fine Adjustment Knob	(1)
66	43-98-0255	Lock Knob Bolt	(1)
67	44-06-0030	LCD Lens Cover	(1)
68	44-10-0155	Detent Lever	(1)
69	44-40-0105	Lock Block	(1)
70	44-60-0495	Hinge Pin	(1)
71	14-46-1275	Service Kerf Plates (Set of 2)	(1)
72	44-66-0265	Table Lock Bracket	(1)
73	44-66-1125	Miter Lock Plate	(1)
74	44-72-0061	Miter Pointer	(1)
75	-----	Handle Lock Rod	(1)
76	45-08-0455	Table Bolt	(1)
77	-----	Compound Pinion Tube	(1)
78	45-88-3045	Washer	(1)
79	-----	Special Washer	(1)
235	14-48-0105	Chassis Assembly	(1)
236	14-48-0085	Table Lock Rod Assembly	(1)
237	14-48-0095	Fine Adjustment Assembly	(1)
238	28-06-1140	Table Assy. (Incl. 3 linear bearings, not shown)	(1)
249	14-48-0096	Slide Block Assembly	(1)



Adjustment hole for Set Screw #33 to calibrate DRO Switch #42

**ADJUSTMENT OF Digital Readout (DRO) CALIBRATION SWITCH:**

- Turn the Calibration Set Screw #33 in (toward Switch #42) enough that the calibration switch contacts will not close.
- With the Miter Detent Spring #54 out of the detent notch in the Miter Detent Scale #20, but resting on the Miter Scale, move the Table #43 about 1.5" to either side of the "0" position and return to the "0" notch.
- Insert a 2.5mm hex key into Set Screw #33 and adjust by turning the screw out (clockwise when viewed from the operators position) until the digital read out changes from the set angle to "0". Turn Set Screw #33 an extra 1/4-1/2 turn out.
- Remove 2.5mm adjustment hex key from Set Screw #33. See *Wiring Instruction* for more detail.

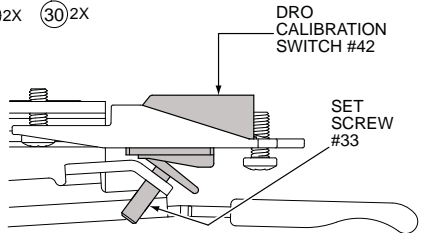

SPECIFY CATALOG NO. AND SERIAL NO. WHEN ORDERING PARTS			REVISED BULLETIN	DATE
<b>12" SLIDING COMPOUND MITER SAW</b>				Apr. 2011
CATALOG NO.	6955-20	SERIAL NUMBER	WIRING INSTRUCTION	
		B26A	<b>58-01-6925</b>	

**EXAMPLE:**  
Component Parts (Small #) Are Included  
When Ordering The Assembly (Large #).

**LUBRICATION NOTES**  
Coat with Type 'Y' grease. No. 49-08-5270.

Diameter and of Bevel Hub #84 to have a coating of grease. Pockets of diameter to be filled with grease.

FIG.	PART NO.	DESCRIPTION OF PART	NO REQ.
80	05-80-0510	M5 x 12mm Flat Head T-20 Screw	(2)
81	05-81-0130	M4 x 8mm Pan Head T-20 Screw	(2)
82	05-86-0650	M5 x .8 x 8mm Hex Socket Set Screw	(1)
83	05-89-0535	M6 x 1 x 13mm Pan Head T-25 Screw	(2)
84	-----	Bevel Hub	(1)
85	42-38-0395	Bumper	(2)
86	43-06-0035	Brake Disk	(1)
87	43-82-0160	Bevel Scale	(1)
88	45-30-0225	Rubber Slug	(1)
89	45-58-0125	Stud	(1)
90	-----	Slide Tube	(2)
91	45-98-0030	Tie Bar	(1)
239	28-53-0350	Bevel Hub Assembly	(1)

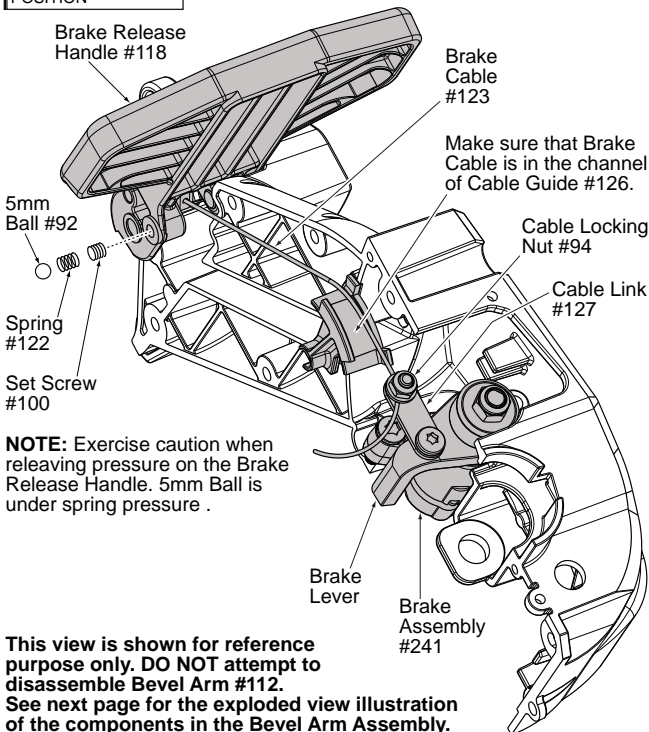
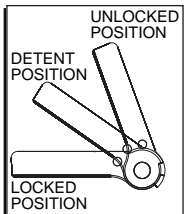
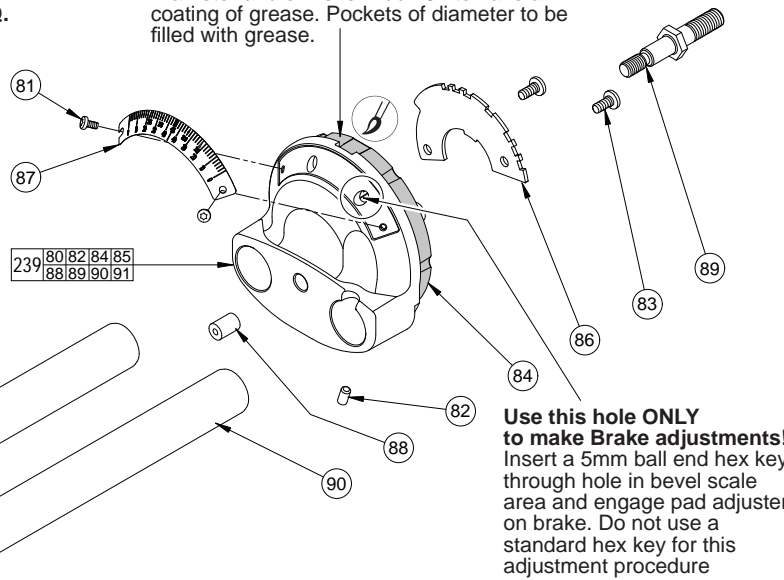

**1. ADJUSTMENT OF BRAKE CABLE:**  
**(Reference next page for Bevel Arm Assembly)**

- A. Start with Bevel Release Handle #118, Brake Cable #123, Bevel Brake #241 and Cable Link #127 assembled in Bevel Arm #112. Cable inserted into Cable Link but not tightened.
- B. Move Bevel Release Handle to detent position.
- C. Move and hold brake release lever in position by use of a gage block.
  - C.1 For Sliding Compound model 6955 use special service fixture No. 61-10-0095.
- D. Pull Cable taught using needle nose pliers.
- E. Tighten Cable Locking Nut #94 to 45-50 in./lb.
- F. Lift Bevel Release Handle to release support of brake lever.
- G. Move Bevel Release Handle to locked position.

**2. ADJUSTMENT OF STATIONARY BRAKE PAD IN BEVEL ARM:**

- A. Remove Dust Chutes #115, #116 and Vertical Air Deflector #117. Release Bevel Brake.
- B. Move Bevel Arm to right side hard stop.
- C. Block Bevel Release Handle to hold Break in the released position.
  - C.1 For Sliding Compound model 6955 use special service fixture No. 61-10-0275.
- D. Remove Bevel Scale Mounting Screw #81 on right side of Bevel Scale #87, loosen Scale Mounting Screw on left side of Scale and remove Bevel Scale.
- E. Insert a 5mm ball end hex key through right hole in bevel scale area of Bevel Hub #84 (see illustration) and engage pad adjuster on Brake. Do not use a standard hex key for this adjustment procedure.
- F. Turn pad adjuster to the right until it stops against the Disk #86.
- G. Turn pad adjuster to the left 1/8 turn.
- H. Remove hex key from break adjuster.
- I. Reassemble Bevel Scale, Vertical Air Deflector and Dust Chutes to saw.

**This view is shown for reference purpose only. DO NOT attempt to disassemble Bevel Arm #112. See next page for the exploded view illustration of the components in the Bevel Arm Assembly.**





**SERVICE PARTS LIST**  
PAGE 4 OF 6 BEVEL ARM ASSY.

**BULLETIN NO.**  
**54-40-6925**

SPECIFY CATALOG NO. AND SERIAL NO. WHEN ORDERING PARTS		REVISED BULLETIN	DATE
<b>12" SLIDING COMPOUND MITER SAW</b>			Apr. 2011
CATALOG NO.	<b>6955-20</b>	SERIAL NUMBER	<b>B26A</b>
		WIRING INSTRUCTION <b>58-01-6925</b>	

**EXAMPLE:**  
Component Parts (Small #)  
Are Included When Ordering  
The Assembly (Large #).

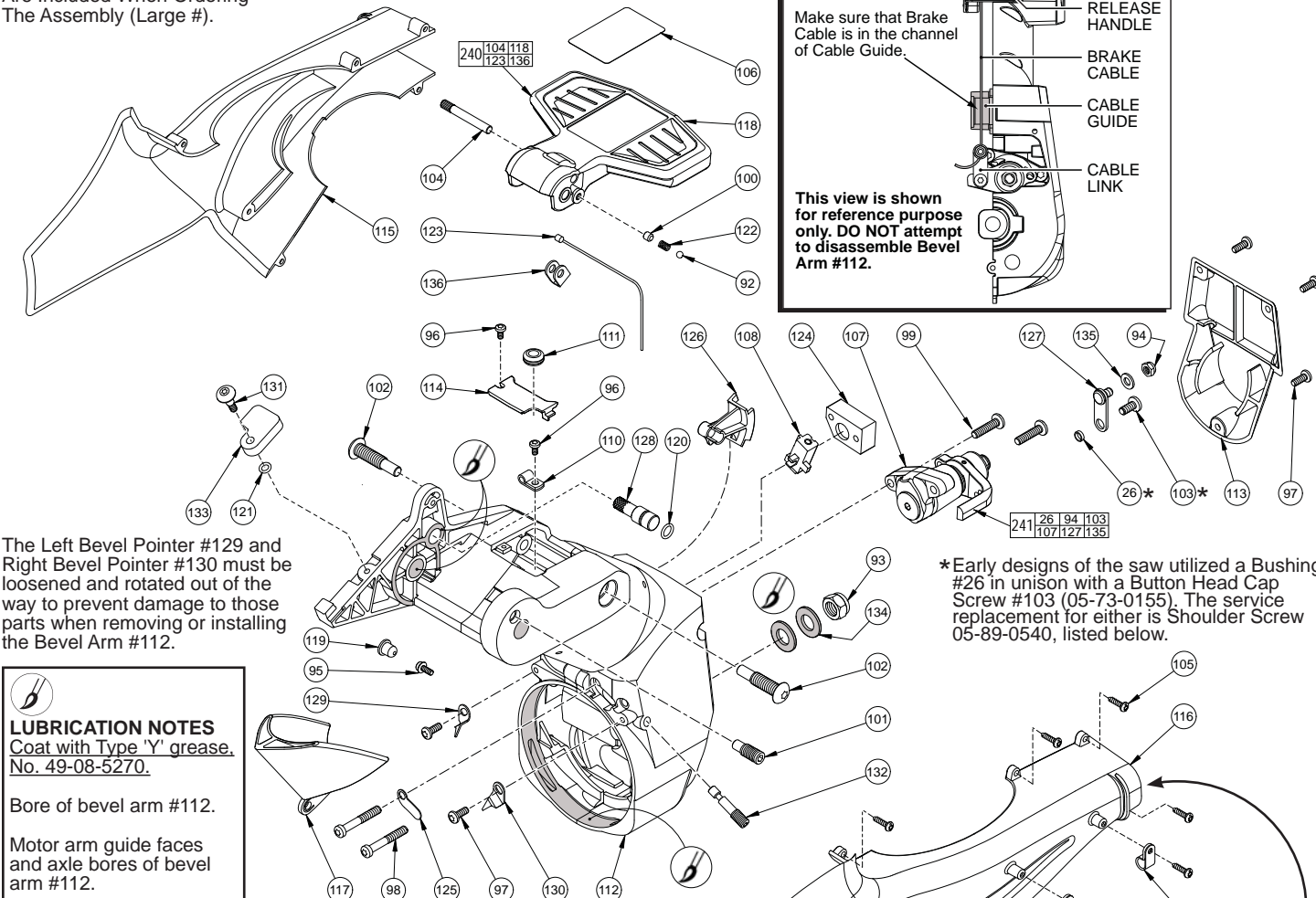

FIG.	PART NO.	DESCRIPTION OF PART	NO REQ.
26	42-40-0945	Bushing	(1)
92	02-02-1300	5mm Ball	(1)
93	05-55-0970	M12 Prevailing Torque Nut	(1)
94	05-55-0965	M6 Prevailing Torque Nut	(1)
95	05-79-0010	M4 x 10mm Hex Socket Washer Hd Scr	(1)
96	05-81-0130	M4 x 8mm Pan Head T-20 Screw	(2)
97	05-81-0135	M5 x 13mm Pan Head T-25 Screw	(5)
98	05-81-0140	M6 x 40mm Pan Head T-25 Screw	(2)
99	05-81-0145	M6 x 25mm Pan Head T-30 Screw	(2)
100	05-86-0655	M6 x 1 x 6mm Hex Socket Set Screw	(1)
101	05-89-0520	M10 x 1.5mm Hex Socket Stop Screw	(1)
102	05-89-0525	M10 x 1.5 x 44mm T-45 Pivot Screw	(2)
103	05-89-0540	8 x 2.5mm Phillips Pan Hd Shoulder Scr	(1)
104	06-65-0530	Dowel Pin	(1)
105	06-82-9220	K40 x 5/8" Pan Hd Slotted T-20 Screw	(8)
106	10-20-9100	Bevel Lock Label	(1)
107	-----	Caliper	(1)
108	14-48-0075	Detent Assembly	(1)
109	22-38-0150	Cable Clamp	(2)
110	22-38-0175	Cable Clamp	(1)
111	22-90-0245	Grommet	(1)
112	28-04-0405	Bevel Arm	(1)
113	31-15-1510	Back Cover	(1)
114	31-15-1515	Bevel Top Cover	(1)
115	31-15-2130	Dust Chute, Left	(1)
116	31-15-2135	Dust Chute, Right	(1)
117	31-15-2155	Deflector Verticale	(1)
118	31-44-2310	Bevel Release Handle	(1)
119	31-53-0235	Plug	(1)
120	34-40-0250	O-Ring	(1)
121	34-40-0255	O-Ring	(1)
122	40-50-3940	Spring	(1)
123	42-44-0005	Cable	(1)

FIG.	PART NO.	DESCRIPTION OF PART	NO REQ.
124	42-68-0050	Detent Clamp	(1)
125	42-92-1145	Detent Cover	(1)
126	43-56-0835	Cable Guide	(1)
127	44-14-0285	Cable Link	(1)
128	44-60-1800	Lock Pin	(1)
129	44-72-0070	Bevel Pointer, Left	(1)
130	44-72-0075	Bevel Pointer, Right	(1)
131	45-04-0020	6 x 10mm Shoulder Screw	(1)
132	45-04-0025	Adjusting Screw	(1)
133	45-52-0100	Dado Stop	(1)
134	45-88-1670	M12 Washer	(2)
135	45-88-3055	Flat Washer	(1)
136	45-98-0035	Cable Yoke	(1)
240	14-34-0605	Bevel Release Handle Assembly	(1)
241	14-04-0100	Brake Assembly	(1)
	31-15-2140	Dust Elbow (Not Shown)	(1)
	42-16-0240	Dust Bag (Not Shown)	(1)



**SERVICE PARTS LIST**  
PAGE 5 OF 6 MOTOR ASSEMBLY

**BULLETIN NO.**  
**54-40-6925**

SPECIFY CATALOG NO. AND SERIAL NO. WHEN ORDERING PARTS		REVISED BULLETIN	DATE
<b>12" SLIDING COMPOUND MITER SAW</b>			Apr. 2011
CATALOG NO.	<b>6955-20</b>	SERIAL NUMBER	<b>B26A</b>
		WIRING INSTRUCTION <b>58-01-6925</b>	

**EXAMPLE:**  
Component Parts (Small #)  
Are Included When Ordering  
The Assembly (Large #).

**SERVICE NOTES:**  
When replacing Light Bulb #172, Use GE 194 Automotive Bulb.

Replacement of Light Bulb #172 must be done by removing Lens #218.  
**DO NOT** attempt removing the Worklight Wiring Harness from the Light Reflector #226.

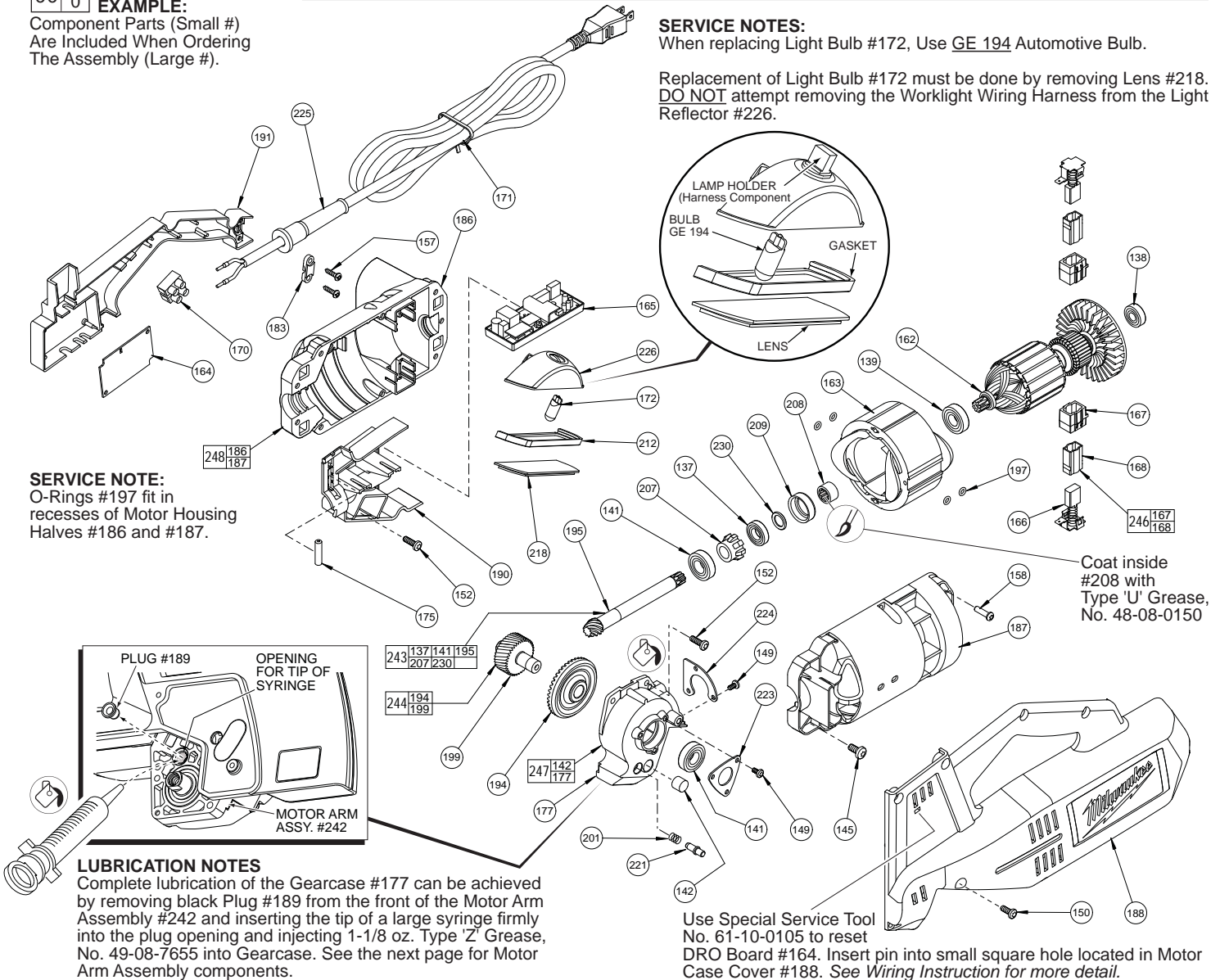

FIG.	PART NO.	DESCRIPTION OF PART	NO REQ.
137	02-04-0100	Ball Bearing	(1)
138	02-04-0852	Ball Bearing	(1)
139	02-04-1212	Ball Bearing	(1)
141	02-08-0510	Ball Bearing	(2)
142	02-50-2150	Needle Bearing	(1)
145	05-73-0155	M6 x 13 Pan Head T-27 Screw	(4)
149	05-81-0130	M4 x 8 Pan Head T-20 Screw	(6)
150	05-81-0135	M5 x 13 Pan Head T-25 Screw	(8)
152	05-81-0155	M5 x 16 Pan Head T-25 Screw	(4)
157	06-82-9220	K40 x 5/8" Slotted T-20 PT Screw	(2)
158	06-95-6290	M5 x 2.24 x 18 Slotted T-20 PT Screw	(9)
162	16-70-5010	Service Armature Assembly	(1)
163	18-70-5000	Service Field	(1)
164	22-09-1060	DRO Board	(1)
165	22-09-1590	120V Motor Control	(1)
166	14-46-1260	Brush Set (Set of 2)	(1)
167	-----	Brush Holder	(2)
168	-----	Brush Tube	(2)
170	22-56-0470	Terminal Block	(1)
171	22-64-6495	120V Cord Set	(1)
172	-----	Light Bulb (See Note)	(1)
175	23-80-0020	Speed Control Sensor	(1)
177	-----	Gear Case	(1)
183	31-17-0155	Cord Clamp	(1)
186	-----	Motor Housing - Left	(1)

FIG.	PART NO.	DESCRIPTION OF PART	NO REQ.
187	-----	Motor Housing - Right	(1)
188	31-50-2210	Motor Case Cover	(1)
190	31-55-0035	Lower Tray	(1)
191	31-55-0040	Upper Tray	(1)
194	-----	Bevel Gear	(1)
195	32-60-0081	Bevel Pinion Shaft	(1)
197	34-40-0260	O-Ring	(4)
199	-----	Pinion Gear	(1)
201	40-50-0390	Spring	(1)
207	42-76-0540	Speed Control Collar	(1)
208	42-90-0095	Coupling	(1)
209	42-96-0080	Bearing Cup	(1)
212	43-44-0055	Gasket	(1)
218	44-06-0115	Lens	(1)
221	44-60-0705	Spindle Lock Pin	(1)
223	44-66-0950	Bearing Plate	(1)
224	44-66-0955	Bearing Plate	(1)
225	44-76-0210	Cord Protector	(1)
226	44-79-0040	Light Reflector	(1)
230	45-36-2010	Spacer	(1)
243	14-29-0240	Bevel Pinion Shaft Assembly	(1)
244	14-29-0250	Gear Service Assembly	(1)
246	22-20-0980	Brush Holder Assembly	(2)
247	14-30-0910	Gear Case Service Assembly	(1)
248	31-50-2206	Motor Housing Assembly	(1)

SPECIFY CATALOG NO. AND SERIAL NO. WHEN ORDERING PARTS		REVISED BULLETIN	DATE
<b>12" SLIDING COMPOUND MITER SAW</b>			Apr. 2011
CATALOG NO.	<b>6955-20</b>	SERIAL NUMBER	<b>B26A</b>
		WIRING INSTRUCTION <b>58-01-6925</b>	

00 0

**EXAMPLE:**

Component Parts (Small #) are Included When Ordering The Assembly (Large #).

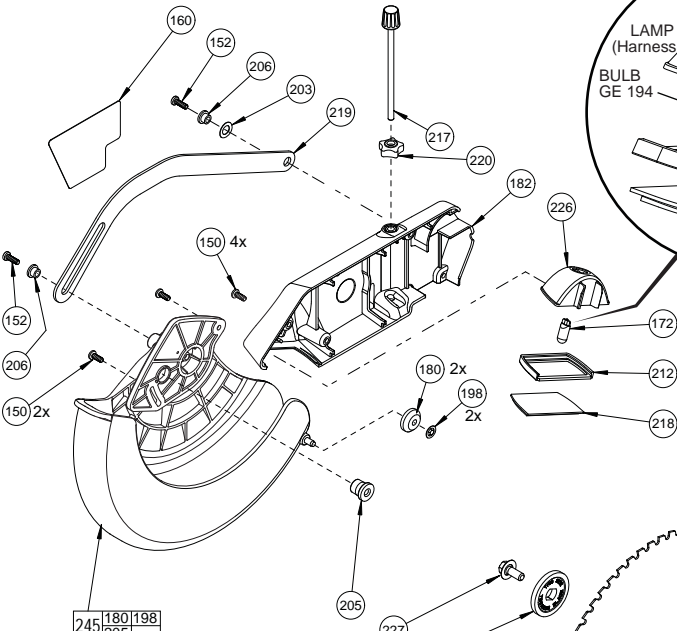

**DO NOT** attempt to disassemble the Lower Blade Guard Assembly #245.

**SERVICE NOTES:**

When replacing Light Bulb #172, Use GE 194 Automotive Bulb.

Replacement of Light Bulb #172 must be done by removing Lens #218. **DO NOT** attempt removing the Worklight Wiring Harness from the Light Reflector #226.

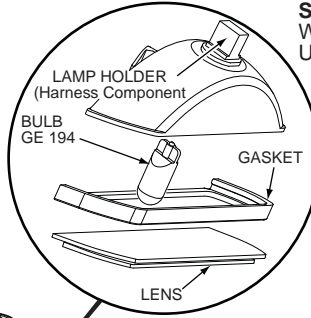

Tapered end of Axle #204 to be inserted first into pivot bores of Motor Arm Assembly #242.

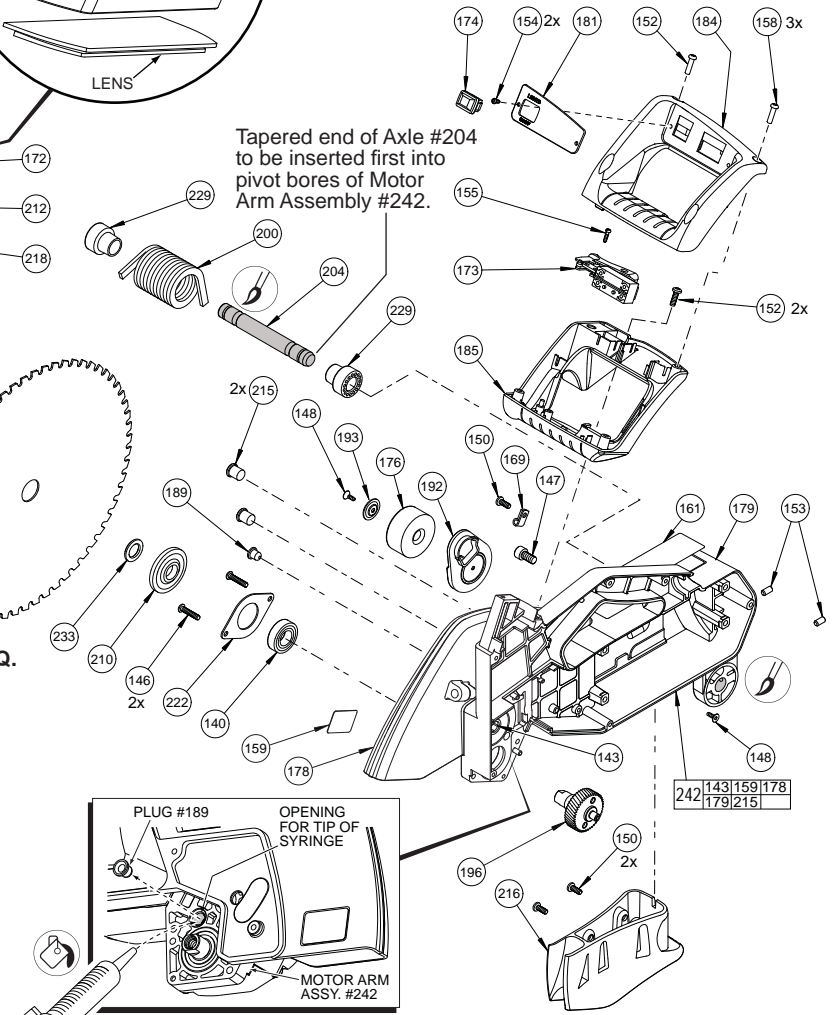

FIG.	PART NO.	DESCRIPTION OF PART	NO REQ.
140	02-04-1700	Ball Bearing	(1)
143	-----	Needle Bearing	(1)
146	05-73-0160	M5 x 25 Button Head T-25 Screw	(2)
147	05-74-0050	M8 x 16 Socket Head Cap Screw	(1)
148	05-80-0500	K40 x 12mm Flat Head T-20 PT Screw	(2)
150	05-81-0135	M5 x 13 Pan Head T-25 Screw	(7)
152	05-81-0155	M5 x 16 Pan Head T-25 Screw	(5)
153	05-86-0645	M6 Set Screw	(2)
154	05-88-5910	M3.5 x 1.57 x 8mm Pan Hd T-10 Screw	(2)
155	05-88-5915	M3.5 x 1.57 x 12mm Pan Hd T-10 Screw	(1)
158	06-95-6290	M5 x 2.24 x 18 Slotted T-20 PT Screw	(3)
159	10-20-9105	Guard Plate Label	(1)
160	10-20-9110	Arm Warning Label	(1)
161	12-20-0095	Service Nameplate	(1)
169	22-38-0175	Cable Clamp	(1)
172	-----	Light Bulb (See Note)	(1)
173	23-66-3035	Switch	(1)
174	23-66-3040	Rocker Switch	(1)
176	23-81-0580	Transformer	(1)
178	-----	Upper Guard	(1)
179	-----	Motor Arm	(1)
180	31-01-2500	Lower Guard Wheel	(2)
181	31-15-2120	Handle Cover	(1)
182	31-15-2125	Transformer Cover	(1)
184	31-44-2325	Top Handle	(1)
185	31-44-2330	Bottom Handle	(1)
189	31-53-0235	Plug	(1)
192	31-55-0400	Transformer Shield	(1)
193	31-55-0405	Washer	(1)
196	32-75-0080	Spindle Gear	(1)
198	34-60-0020	External Retaining Ring	(2)
200	40-50-0385	Torsion Spring	(1)
203	40-50-3945	Spring washer	(1)
204	42-12-0045	Axle	(1)
205	42-38-0390	Bumper	(1)
206	42-40-0935	Bushing	(2)
210	43-34-0865	Inner Blade Flange	(1)
211	43-34-0870	Outer Blade Flange	(1)
212	43-44-0055	Gasket	(1)
215	43-56-0825	Blade Deflector	(2)
216	43-56-0830	Chip Deflector	(1)
217	43-98-0290	Depth Adjust Knob	(1)

**LUBRICATION NOTES**

Complete lubrication of Gearcase #177 (see previous page) can be achieved by removing black Plug #189 from the front of the Motor Arm Assembly #242 and inserting the tip of a large syringe firmly into the plug opening and injecting 1-1/8 oz. Type 'Z' Grease, No. 49-08-7655 into Gearcase.

**LUBRICATION NOTES**

Fill outer grooves and coat surface of Axle #204 with Type 'Y' Grease, No. 49-08-5270.

Coat pivot bores of Motor Arm Assembly #242 with Type 'Y' Grease.

FIG.	PART NO.	DESCRIPTION OF PART	NO REQ.
218	44-06-0115	Lens	(1)
219	44-14-0280	Guard Link	(1)
220	44-40-0100	Depth Lock Nut	(1)
222	44-66-0945	Bearing Plate	(1)
226	44-79-0040	Light Reflector	(1)
227	45-04-0925	Blade Screw	(1)
229	45-36-1640	Spring Support Bushing	(2)
233	45-36-2025	Blade Spacer	(1)
234	42-41-4545	12" Miter Saw Blade	(1)
242	14-38-0690	Motor Arm Assembly	(1)
245	14-32-0205	Lower Blade Guard Assembly	(1)

