

# **JET**

**EQUIPMENT & TOOLS**

## **OPERATOR'S MANUAL**

### **JTM-1050 Turret Mill**



**JET EQUIPMENT & TOOLS, INC.**  
A WMH Company

P.O. BOX 1349  
Auburn, WA 98071-1349

253-351-6000  
Fax 253-939-8001

M-690050 5/98

# Important Information

**1 YEAR  
LIMITED WARRANTY**

**JET offers a one year limited  
warranty on this product**

## REPLACEMENT PARTS

Replacement parts for this tool are available directly from JET Equipment & Tools.

To place an order, call 1-800-274-6848. Please have the following information ready:

1. Visa, MasterCard, or Discover Card number
2. Expiration date
3. Part number listed within this manual
4. Shipping address other than a Post Office box.

## REPLACEMENT PART WARRANTY

JET Equipment & Tools makes every effort to assure that parts meet high quality and durability standards and warrants to the original retail consumer/purchaser of our parts that each such part(s) to be free from defects in materials and workmanship for a period of thirty (30) days from the date of purchase.

## PROOF OF PURCHASE

Please retain your dated sales receipt as proof of purchase to validate the warranty period.

## LIMITED TOOL AND EQUIPMENT WARRANTY

JET makes every effort to assure that its products meet high quality and durability standards and warrants to the original retail consumer/purchaser of our products that each product be free from defects in materials and workmanship as follows: **1 YEAR LIMITED WARRANTY ON THIS JET PRODUCT.** Warranty does not apply to defects due directly or indirectly to misuse, abuse, negligence or accidents, repairs or alterations outside our facilities or to a lack of maintenance. **JET LIMITS ALL IMPLIED WARRANTIES TO THE PERIOD SPECIFIED ABOVE FROM THE DATE THE PRODUCT WAS PURCHASED AT RETAIL. EXCEPT AS STATED HEREIN, ANY IMPLIED WARRANTIES OR MERCHANTABILITY AND FITNESS ARE EXCLUDED. SOME STATES DO NOT ALLOW LIMITATIONS ON HOW LONG THE IMPLIED WARRANTY LASTS, SO THE ABOVE LIMITATION MAY NOT APPLY TO YOU. JET SHALL IN NO EVENT BE LIABLE FOR DEATH, INJURIES TO PERSONS OR PROPERTY OR FOR INCIDENTAL, CONTINGENT, SPECIAL OR CONSEQUENTIAL DAMAGES ARISING FROM THE USE OF OUR PRODUCTS. SOME STATES DO NOT ALLOW THE EXCLUSION OR LIMITATION OF INCIDENTAL OR CONSEQUENTIAL DAMAGES, SO THE ABOVE LIMITATION OR EXCLUSION MAY NOT APPLY TO YOU.** To take advantage of this warranty, the product or part must be returned for examination, postage prepaid, to an authorized service station designated by our Auburn office. Proof of purchase date and an explanation of the complaint must accompany the merchandise. If our inspection discloses a defect, JET will either repair or replace the product or refund the purchase price, if we cannot readily and quickly provide a repair or replacement, if you are willing to accept such refund. JET will return repaired product or replacement at JET's expense, but if it is determined there is no defect, or that the defect resulted from causes not within the scope of JET's warranty, then the user must bear the cost of storing and returning the product. This warranty gives you specific legal rights, and you have other rights which vary from state to state.

 **WARNING**

- **Read and understand the entire instruction manual before attempting set-up or operation of this machine.**
- Always wear approved safety glasses/face shields while using this machine.
- Make certain the machine is properly grounded.
- Before operating the machine, remove tie, rings, watches, other jewelry, and roll up sleeves above the elbows. Remove all loose clothing and confine long hair. Do **not** wear gloves.
- Keep the floor around the machine clean and free of scrap material, oil and grease.
- Keep machine guards in place at all times when the machine is in use. If removed for maintenance purposes, use extreme caution and replace the guards immediately.
- Do **not** over reach. Maintain a balanced stance at all times so that you do not fall or lean against blades or other moving parts.
- Make all machine adjustments or maintenance with the machine unplugged from the power source.
- Use the right tool. Don't force a tool or attachment to do a job which it was not designed for.
- Replace warning labels if they become obscured or removed.
- Make certain the motor switch is in the **OFF** position before connecting the machine to the power supply.
- Give your work undivided attention. Looking around, carrying on a conversation, and "horse-play" are careless acts that can result in serious injury.
- Keep visitors a safe distance from the work area.
- Use recommended accessories; improper accessories may be hazardous.
- Keep hands away from all moving parts (belts, cutters, gears, etc.).
- Never operate this machine under the influence of alcohol or drugs.
- Some coolants used for machining contain chemicals that may be hazardous to your health if not used properly. Read and understand all user information listed on the coolant container and protect yourself accordingly.
- Read and understand all warnings posted on the machine.
- This manual is intended to familiarize you with the technical aspects of this milling machine. It is not, nor was it intended to be, a training manual.
- **This machine is designed and intended for use by properly trained and experienced personnel only. If you are not familiar with the proper safe use of milling machines, do not use this machine until proper training and knowledge has been obtained.**
- Failure to comply with all of these warnings may cause serious injury.

## Specifications

JTM-1050

Stock Number .....	690050
Spindle Taper .....	R-8
Diameter of Quill .....	3.375"
Number of Spindle Speeds .....	Variable
Range of Spindle Speeds .....	80 to 3800 RPM
Downfeeds per Revolution of Spindle .....	.0015", .003", .006"
Spindle Travel .....	5"
Head Movement .....	90°L and R 45°F and B
Maximum Distance Spindle Nose to Table .....	19"
Maximum Distance Spindle Center to Column .....	26 1/2"
Minimum Distance Spindle Center to Column .....	6"
Table Size .....	10"×50"
Longitudinal Table Travel .....	35"
Table Cross Travel .....	16"
Number of T-Slots .....	3
Size and Spacing of T-Slots .....	5/8"×2-1/2"
Maximum Table Load .....	720Lbs.
Knee Travel .....	16 1/2"
Overall Dimensions .....	96 1/4"W×77"D×87 3/4"H
Motot .....	3HP, 3ph., 230/460V Prewired 230V
Net Weight (approx.) .....	2820Lbs.

## Table of Contents

Important Information .....	1
Warnings .....	2
Specifications .....	3
Table of Contents .....	3
Installation Layout .....	4
Shipping Container Contents .....	5
Unpacking and Clean-Up .....	5
Site Preparation .....	5
Lifting the Mill .....	5
Lubrication .....	6
Electrical Connections .....	7
Controls .....	7-9
Operating Precautions .....	9
Changing Speed Range .....	10
Setting Up for Fine Hand Feed .....	10
Setting Up for Automatic Feed .....	11
Adjustments .....	11-12
Parts Lists and Breakdowns .....	13-27
Electrical Schematic .....	28

The specifications in this manual are given as general information and are not binding. JET Equipment and Tools reserves the right to effect, at any time and without prior notice, changes or alterations to parts, fittings, and accessory equipment deemed necessary for any reason whatsoever.

# JTM-1050 Installation Layout

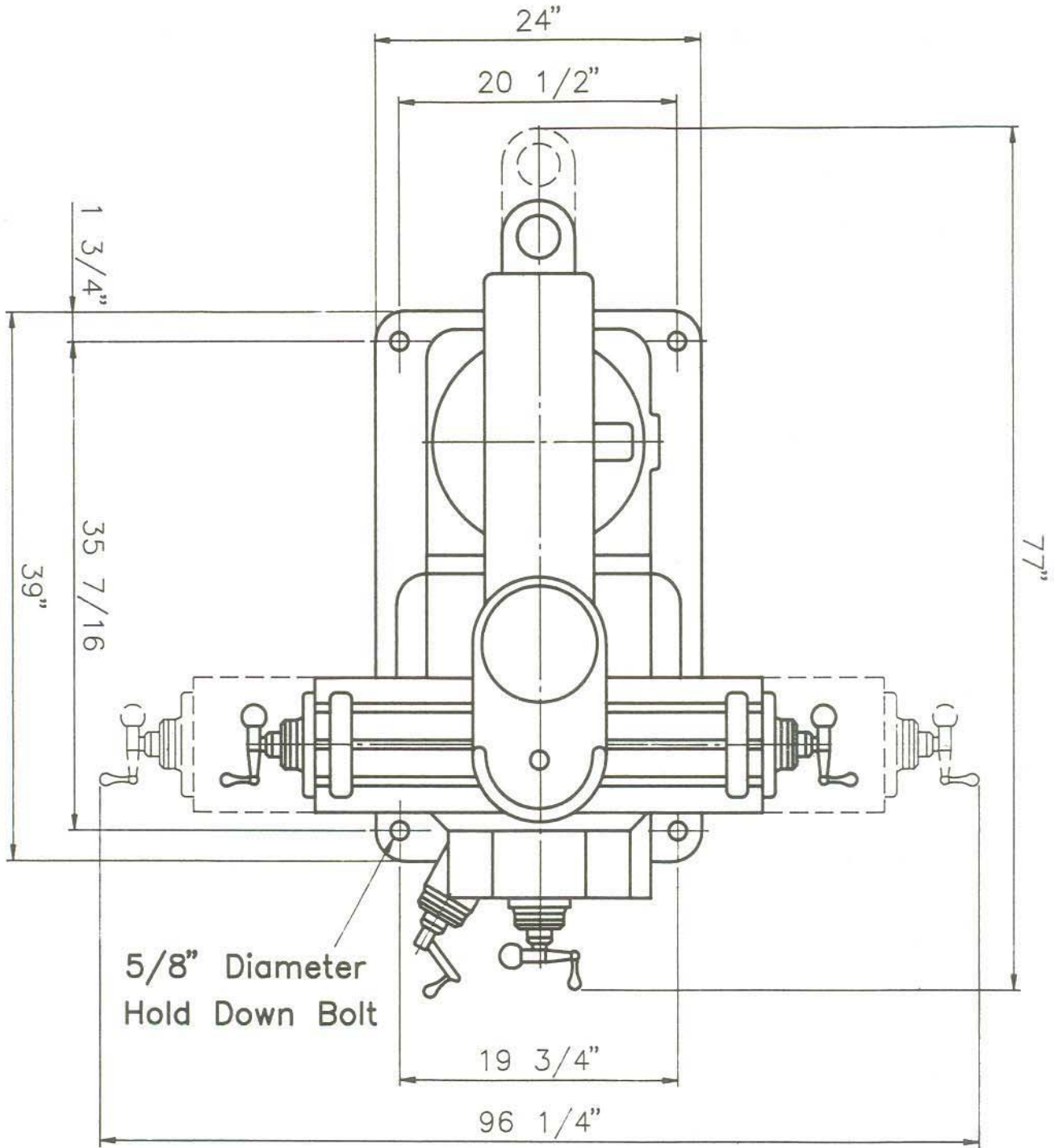

Fig. 1

## Shipping Container Contents

- 1 Mill
- 1 Flat Way Cover (rear)
- 1 Accordion Way Cover (front)
- 1 Tool Box:
  - 1 Hex Wrench Set (1.5 - 10mm)
  - 1 19mm Combination Wrench
  - 1 #2 Cross Point Screw Driver
  - 1 #2 Flat Blade Screw Driver
  - 1 Plastic Oil Can
  - 1 Operator's Manual
  - 1 Warranty Card
  - 1 Eye Bolt

## Unpacking and Clean-Up

1. Finish removing the sides and top of the crate.  
Leave the mill bolted to the skid until it is ready to move to its final location.
2. Clean all rust protected surfaces with kerosene or a light solvent. Do not use gasoline, paint thinner, or lacquer thinner. These will damage painted surfaces.
3. Cover all machined surfaces with a film of light machine tool oil to inhibit rust.

## Site Preparation

 **Caution**

**Mill must be supported equally under all four corners. Failure to comply may cause the column to twist and put a bind in the bedways.**

The mill must be placed on an even surface and bolted to the floor. Anchor bolts of sufficient size and length must be fastened to the floor according to the footprint of the mill. See Fig. 1.

## Lifting the Mill

The preferred method for lifting the mill is with a hook through the eye bolt screwed into the tapped hole on the ram. Be careful to steady the mill to prevent it from spinning.

An alternative method for lifting the mill is with a sling. Follow the diagram in Fig. 2 for the proper position of the sling under the ram. Note the position of the ram and that the table has been moved against the column. Tighten ram locking bolts (A, Fig. 2) before lifting.

Carefully lift the mill and move to a position over the anchor bolts. Lower the mill over the anchor bolts, check for level, and secure with washers and anchor bolt nuts.

Check the mill for level with a machinist's level placed on the table. Mill must be level back to front and side to side. Shim if necessary, but remember that the mill must be supported equally at all four corners. Check for level before tightening the anchor bolt nuts and after tightening them. Adjust as necessary.

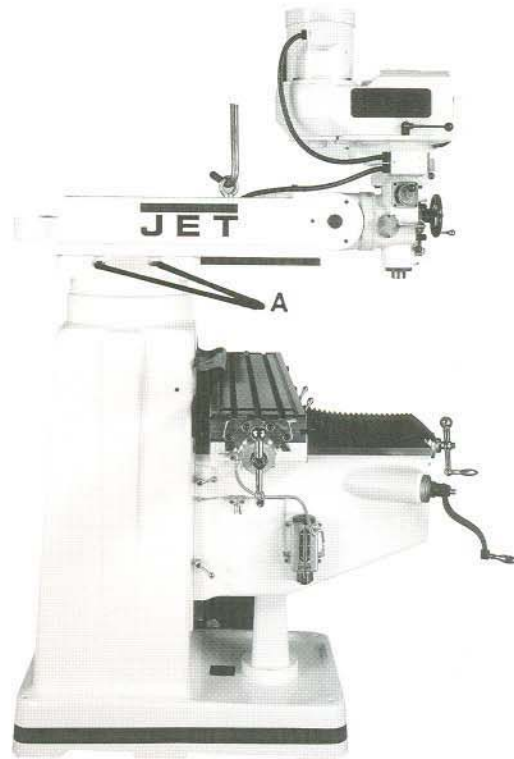



Fig.2

## Lubrication

 **Caution**

**Do not operate the mill before lubricating the machine fully. Failure to comply may cause damage to the machine.**

Reference Fig. 3 for parts of the mill to lubricate:

- A. Spindle Bearings - fill oil cup once daily with 10W machine oil
- B. Oil Pump - fill reservoir as needed by removing cap on top of tank and filling with 10W machine oil. Pump oil with release handle once for every hour of operation. Way surfaces and leadscrews are lubricated in this manner.
- C. Knee Leadscrew - lubricate with #2 tube grease once weekly.

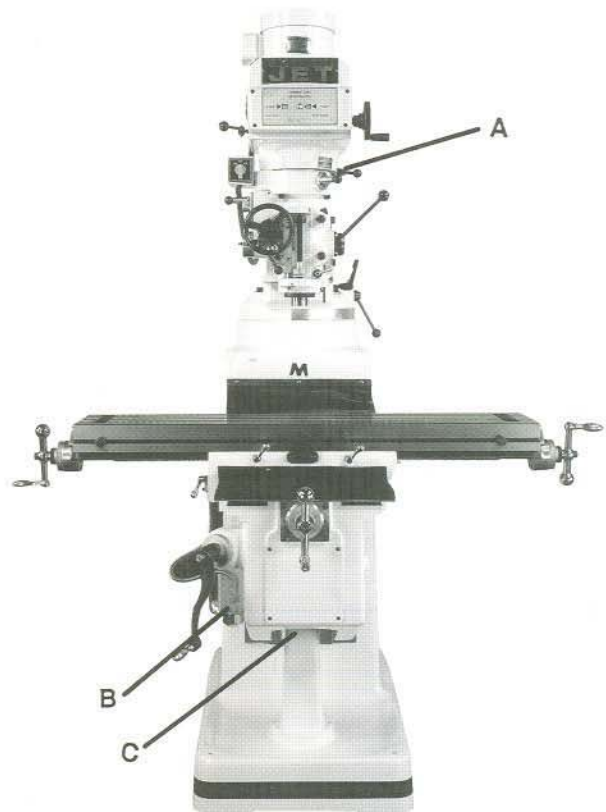

Fig.3

## Electrical Connections

 **WARNING**

**All electrical connections must be made by a qualified electrician!  
Failure to comply may cause serious injury!**

The JTM-1050 mill is rated at 230/460V and comes from the factory prewired at 230V.

Confirm power at the site matches power requirements of the mill before connecting to the power source.

To change from 230V to 460V operation, remove the junction box cover on the rear of the motor and change the wires according to the diagram found on the inside of the cover.

The mill must be properly grounded.

Check for proper spindle rotation in the high speed range. The spindle should rotate clockwise when viewed from the top of the machine. If the spindle rotates counter-clockwise, switch two of the three power leads.

### Controls

- A. **Variable Speed Control** (A, Fig. 4) - located on the right side of the head assembly. Turn clockwise or counter-clockwise to adjust spindle speed. **Caution:** change speed only when spindle is turning.
- B. **Variable Speed Dial Indicator** (B, Fig. 4) - located on the front of the head assembly. Indicates selected speed in high or low range.
- C. **Spindle Brake** (C, Fig. 4) - located on left side of the head. Move in either direction to stop spindle once power has been turned off.

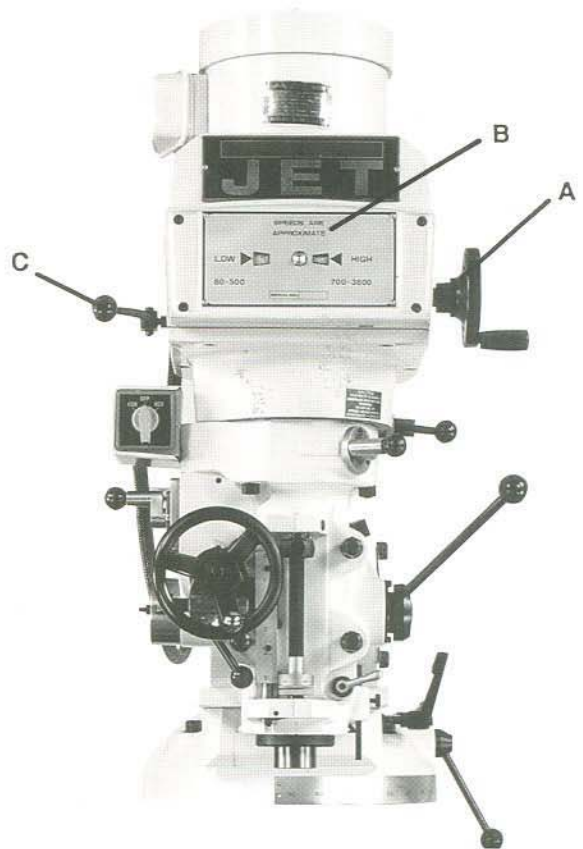

Fig.4



- D. **High-Neutral-Low Lever** (D, Fig. 5) - located on the right side of the head. Upper position is high speed (direct drive). Middle position is neutral. Lower position is low speed (back gear).

**Caution**

**Do not shift High-Low Gear while motor is running. Rotate the spindle by hand to facilitate changing lever positions.**

- E. **Power Feed Transmission Engagement Crank** (E, Fig. 5) - located on right side of head. When lever is in the right hole, the power feed worm gear is disengaged. To engage power feed, pull knob out and move lever around to opposite hole. Engage pin in hole.

**Caution**

**Engage gently to avoid damage to the worm gear.**  
**Power feed may be engaged when spindle is rotating, however, it must be engaged gently to avoid damage to the worm gear.**  
**Do not use power feed at speeds above 3000 R.P.M.**  
**It is recommended that the power feed worm gear be disengaged whenever the power feed is not required. This avoids unnecessary wear on the worm gear.**

- F. **Quill Feed Handle** (F, Fig. 5) - located on right side of head. Rotate clockwise to lower spindle. Return spring will retract the spindle automatically once the handle is released.
- G. **Quill Lock** (G, Fig. 5) - located on the right side of the head. Rotate the handle clockwise to lock the quill in a desired position. Rotate the handle counter-clockwise to release.
- H. **Micrometer Adjusting Nut** (H, Fig. 5), - located on the front of the head. Use for setting specific spindle depth.
- I. **Feed Control Lever** (I, Fig. 5) - located on the left side of the head. Engages overload clutch on pinion shaft when positioned to the left. Stays engaged until quill stop comes in contact

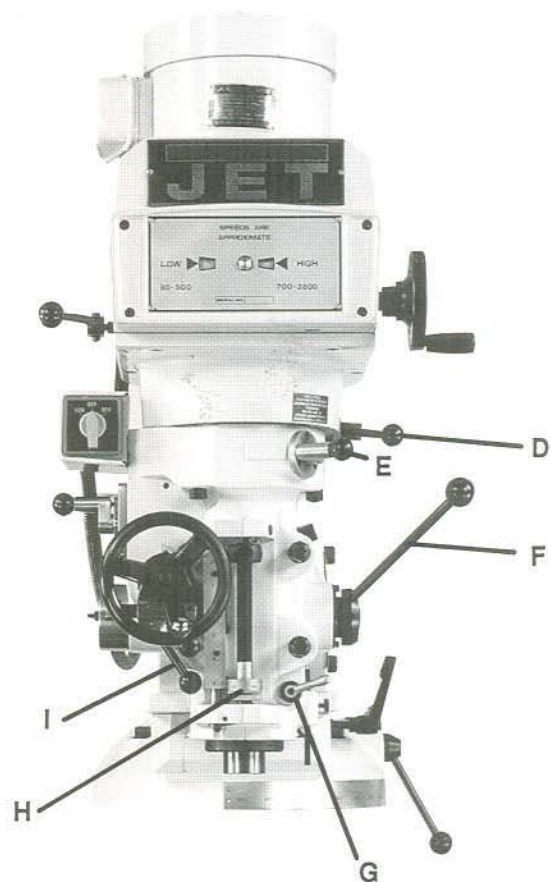

Fig.5

with micrometer adjusting nut (forcing feed control lever to drop out automatically), or until lever is released manually by engaging lever to the right.

- J. **Manual Feed** (J, Fig. 6) - located on the left side of the head. Feed reversing knob (K, Fig. 6) must be in the neutral position. The feed control lever (I, Fig. 6) must be engaged.

**Note:** manual feed handle and handwheel may be taken off when not in use.

- K. **Feed Reversing Knob** (K, Fig. 6) - located in center of manual feed handwheel. Position of the handle depends upon the direction of spindle rotation. If boring with right hand cutting tools, pull feed handle towards operator until clutch becomes engaged. Neutral position is between forward and reverse position.

#### Caution

It is recommended that the handle be left in the neutral position when not in use.

- L. **Quill Stop** (L, Fig. 6) - located on the front of head. Used to disengage the automatic feed in either direction as well as the setting point for working to a given depth.
- M. **Quill Feed Speed Selector** (M, Fig. 6) - located on the left side of the head. Pull knob out and locate handle over choice of three feed speeds - .0015", .003", .006" Downfeeds per spindle revolution. Feed is more readily engaged when spindle is turning.
- N. **Reversing Switch** (N, Fig. 6) - located on the left side of the head. Switches rotation of spindle.

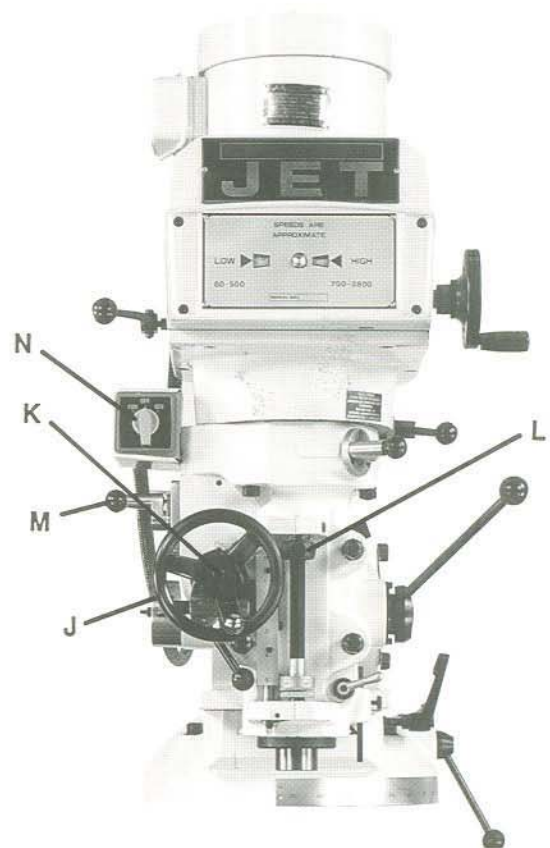

Fig.6

## Operations

### Operating Precautions

1. Do not attempt to change spindle RPM while motor is stopped.
2. Be certain the spindle brake is released before starting the motor.

3. Rotate the spindle by hand to facilitate meshing of the clutch and gears.
4. Do **not** use the quill power feed at speeds above 3000 RPM.
5. It is recommended that the power feed worm gear be disengaged whenever the power feed is not required. This will avoid unnecessary wear on the worm gear.
6. The power feed can be used for drills up to 3/8" in diameter (in mild steel). Use manual feed for drills larger than 3/8".
7. Overload clutch is factory set to hold up to 200 lbs. down feed pressure on the quill (accommodates drills up to 3/8"). Do **not** attempt to adjust clutch pressure.
8. Only change spindle speeds while the motor is running.

### Changing Speed Range

#### Caution

**It is recommended to rotate the spindle by hand to ensure the clutch is engaged prior to turning on. Do not turn on the machine unless the spindle can be moved freely.**

To change from high to low speed range, move lever (D, Fig. 7) by pressing in and rotating almost 180°. Lever will stay in place once pressure is released.

### Setting Up for Fine Hand Feed

1. Disengage automatic feed by pulling out knob (A, Fig. 7) and moving lever to the right hole.
2. Locate the feed reversing knob (C, Fig. 7) in the center or neutral position.
3. Engage feed trip lever (B, Fig. 7) by pulling away from head assembly.

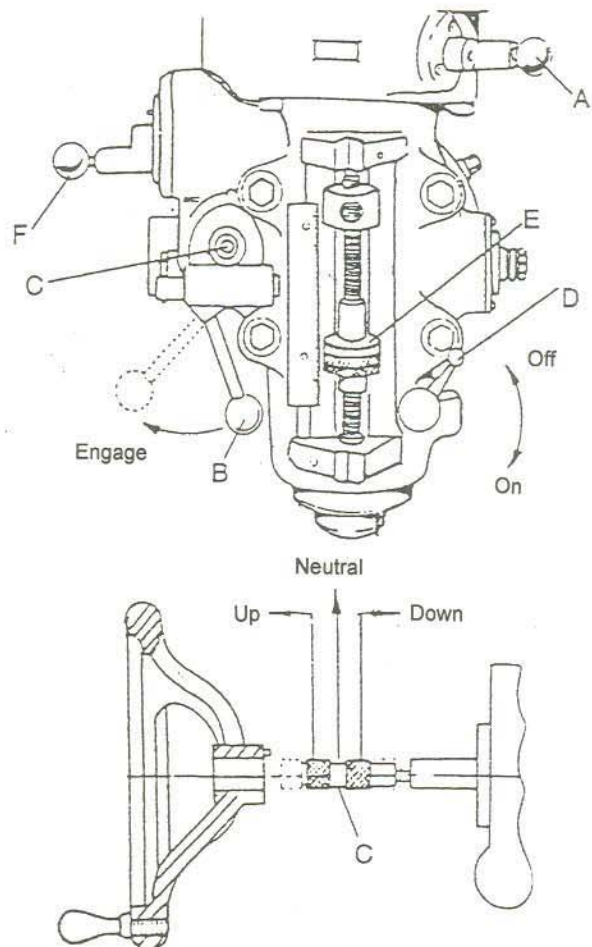

Fig. 7

### Setting Up for Automatic Feed

1. Ensure quill lock (D, Fig. 8) is off by rotating counter-clockwise.
2. Set micrometer dial (E, Fig. 8) to desired depth.
3. Engage auto quill feed lever (A, Fig. 8) by pulling out lock knob and moving lever to the left hole.
4. Select feed rate (F, Fig. 8).
5. Select feed direction (C, Fig. 8)
6. Engage feed trip lever (B, Fig. 8) by pulling away from head assembly.

### Adjustments

#### Feed Trip Adjustment

1. Loosen locknut (A, Fig. 9).
2. Engage trip handle (C, Fig. 9) by pulling away from head assembly.
3. Adjust micro nuts (E, Fig. 9) against quill stop (B, Fig. 9)
4. Slowly turn adjusting screw (D, Fig. 9) until lever (C, Fig. 9) trips.
5. Tighten locknut (A, Fig. 9)

#### Knee Gib Adjustment

**Note:** when adjusting the gibs for the knee, the saddle, and the table always start with the knee first. Adjust the saddle second, and adjust the table last.

Adjust gib screws through wiper on either side of the knee where it meets the column.

#### Saddle Adjustment

Adjust gib screw found on the left front side of the carriage.

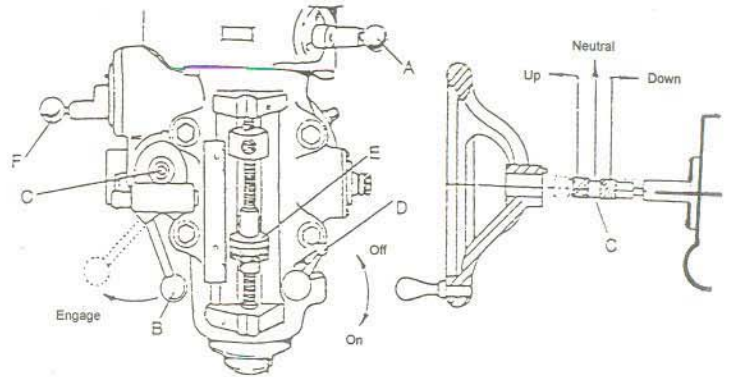

Fig. 8

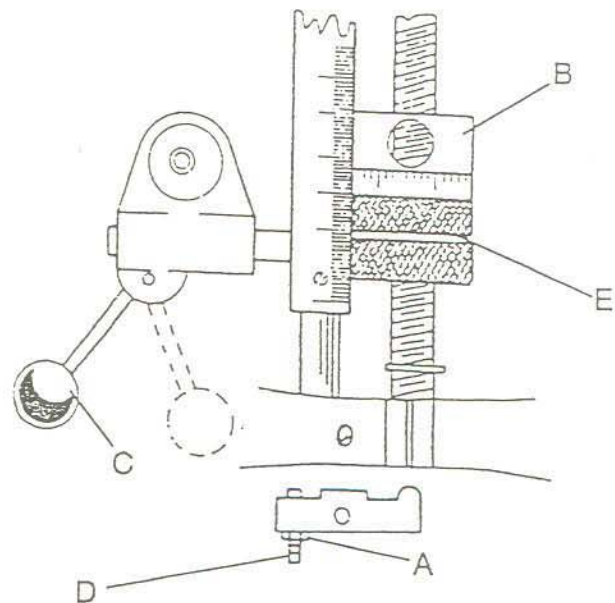

Fig. 9

### **Table Adjustment**

Adjust gib screws found on the sides of the table toward the front of the carriage.

### **Head Alignment**

The scale on the ram adapter and for head rotation (Fig. 10) are guides only. Close tolerance work will require the use of a dial indicator to make sure the head is 90° to the table in the X and Y axis. Please note the table is fitted to be slightly higher in the front, usually about .0005".



Fig.10

# Variable Speed Head Assembly

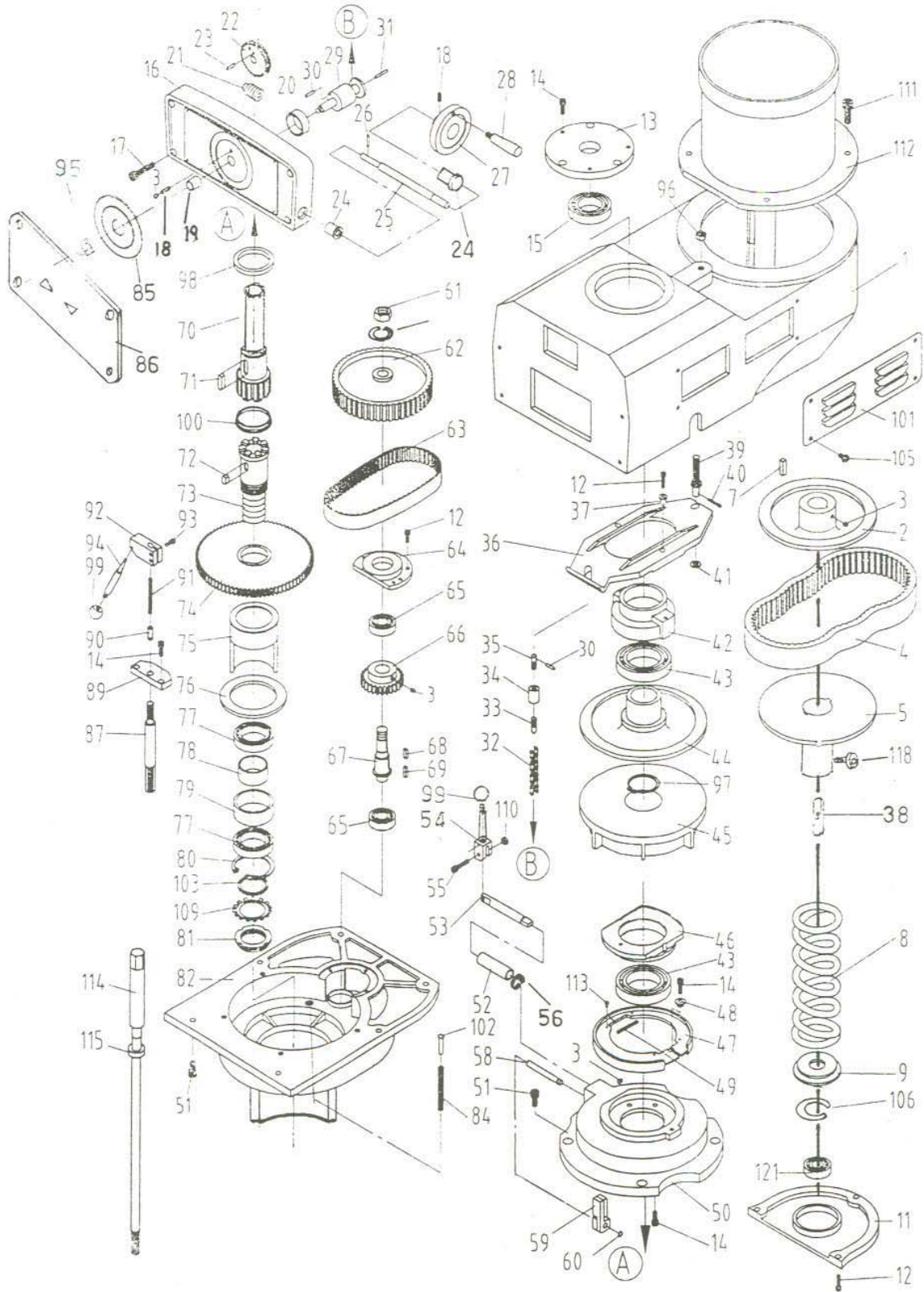

**Parts List for the JTM-1050Turret Mill  
Variable Speed Head Assembly**

Index No.	Part No.	Description	Size	Qty.
1	PVS-001	Housing		1
2	PVS-002	Motor Pulley		1
3	TS-1523011	Set Screw	M6*6	4
4	PVS-004	Belt	3830900	1
5	PVS-005	Motor Pulley		1
7	KEY7725	Key	7*7*25	1
8	PVS-008	Motor Pulley Spring		1
9	PVS-009	Spring Stop Washer		1
11	PVS-011	Motor Pulley Cover		1
12	TS-1502051	Hex Socket Cap Screw	M5*20	9
13	PVS-013	Cover		1
14	TS-1502041	Hex Socket Cap Screw	M5*16	10
15	BB-6007ZZ	Ball Bearing	6007ZZ	1
16	PVS-016	Dial Cover		1
17	TS-1502081	Hex Socket Cap Screw	M5*35	4
18	TS-1503041	Hex Socket Cap Screw	M6*16	3
19	PVS-019	Bushing		1
20	PVS-020	Bushing		1
21	PVS-021	Worm		1
22	PVS-022	Worm Gear		1
23	PVS-023	Spring Pin	5*10	2
24	PVS-024	Bushing		2
25	PVS-025	Dial Control Shaft		1
26	PVS-026	Spring Pin	3x12	2
27	PVS-027	Dial Wheel		1
28	PVS-028	Wheel Handle		1
29	PVS-029	Shaft		1
30	PVS-030	Spring Pin	4*35	2
31	PVS-031	Spring Pin	3*25	1
32	PVS-032	Speed Change Chain		1
33	PVS-033	Adjustment Stud		1
34	PVS-034	Sleeve Nut		1
35	PVS-035	Adjustment Stud		1
36	PVS-036	Tilter		1
37	PVS-037	Bushing		2
38	KEY8760	Key	8*7*60	2
39	PVS-039	Regulating Screw		1
40	PVS-040	Spring Pin	4*12	1
41	PVS-041	Washer		1
42	PVS-042	Support		1
43	BB-6010ZZ	Ball Bearing	6010ZZ	2
44	PVS-044	Drive Pulley Assembly		1
45	PVS-045	Steady Pulley		1
46	PVS-046	Bearing Cover		1

47	PVS-047	Brake Lining		1
48	PVS-048	Lock Screw		1
49	PVS-049	Brake Spring		2
50	PVS-050	Lower Housing Cover		1
51	TS-1503051	Hex Socket Cap Screw	M6*20	10
52	PVS-052	Brake Shaft Sleeve		1
53	PVS-053	Brake Lock Shaft		1
54	PVS-054	Brake Lock Block		1
55	TS-1503061	Hex Socket Cap Screw	M6*25	1
56	PVS-056	Snap Ring	S-12	1
58	PVS-058	Brake Finger Pivot Stud		1
59	PVS-059	Brake Stud		2
60	PVS-060	Snap Ring	S-8	1
61	PVS-061	Nut	5/8"-18NF	1
62	PVS-062	Timing Belt Pulley		1
63	PVS-063	Timing Belt	225L100	1
64	PVS-064	Bearing Housing		1
65	BB-6203ZZ	Ball Bearing	6203ZZ	2
66	PVS-066	Bull Gear		1
67	PVS-067	Counter Shaft		1
68	KEY5515	Key	5*5*15	1
69	KEY5518	Key	5*5*18	1
70	PVS-070	Spindle Pulley Hub		1
71	KEY8720	Key	8*7*20	1
72	KEY8712	Key	8*7*12	1
73	PVS-073	Spindle Gear Hub		1
74	PVS-074	Gear		1
75	PVS-075	Rack Cup		1
76	PVS-076	Washer		1
77	BB-6908ZZ	Ball Bearing	6908ZZ	2
78	PVS-078	Bearing Washer		1
79	PVS-079	Bearing Washer		1
80	PVS-080	Snap Ring	C-62	1
81	PVS-081	Nut		1
82	PVS-082	Housing		1
84	PVS-084	Spring		3
85	PVS-085	Vari-Speed Plate		1
86	PVS-086	Plastic Face Plate		1
87	PVS-087	Gear Shaft Pinion		1
89	PVS-089	Deter Plate		1
90	PVS-090	Bearing Stop		1
91	PVS-091	Spring		1
92	PVS-092	Pinion Block		1
93	TS-1503011	Hex Socket Cap Screw	M5*14	2
94	PVS-094	Pinion Crank		1
95	PVS-095	Cap Nut		1
96	PVS-096	Nut	3/8"	1
98	PVS-098	Wave Washer		1
99	PVS-099	Plastic Ball		2
100	PVS-100	Collar		1
101	PVS-101	Cover		2
102	PVS-102	Spring Shaft		3
103	PVS-103	Washer		1
105	PVS-105	Round Head Screw	3/16"*3/8"	8



106	PVS-106	Snap Ring	S-28	1
109	PVS-109	Lock Washer		1
110	TS1540041	Nut	M6	1
111	TS-0209051	Hex Socket Cap Screw	3/8"*1"	2
112	PVS-112	Motor		1
113	PVS-113	Round Head Screw	1/8"*1/4"	4
114	PVS-114	Draw Bar		1
115	PVS-115	Draw Bar Washer		1
118	PVS-118	Hex Socket Cap Screw	M5*6	1
121	BB-6024ZZ	Ball Bearing	6204ZZ	1

# Head Assembly

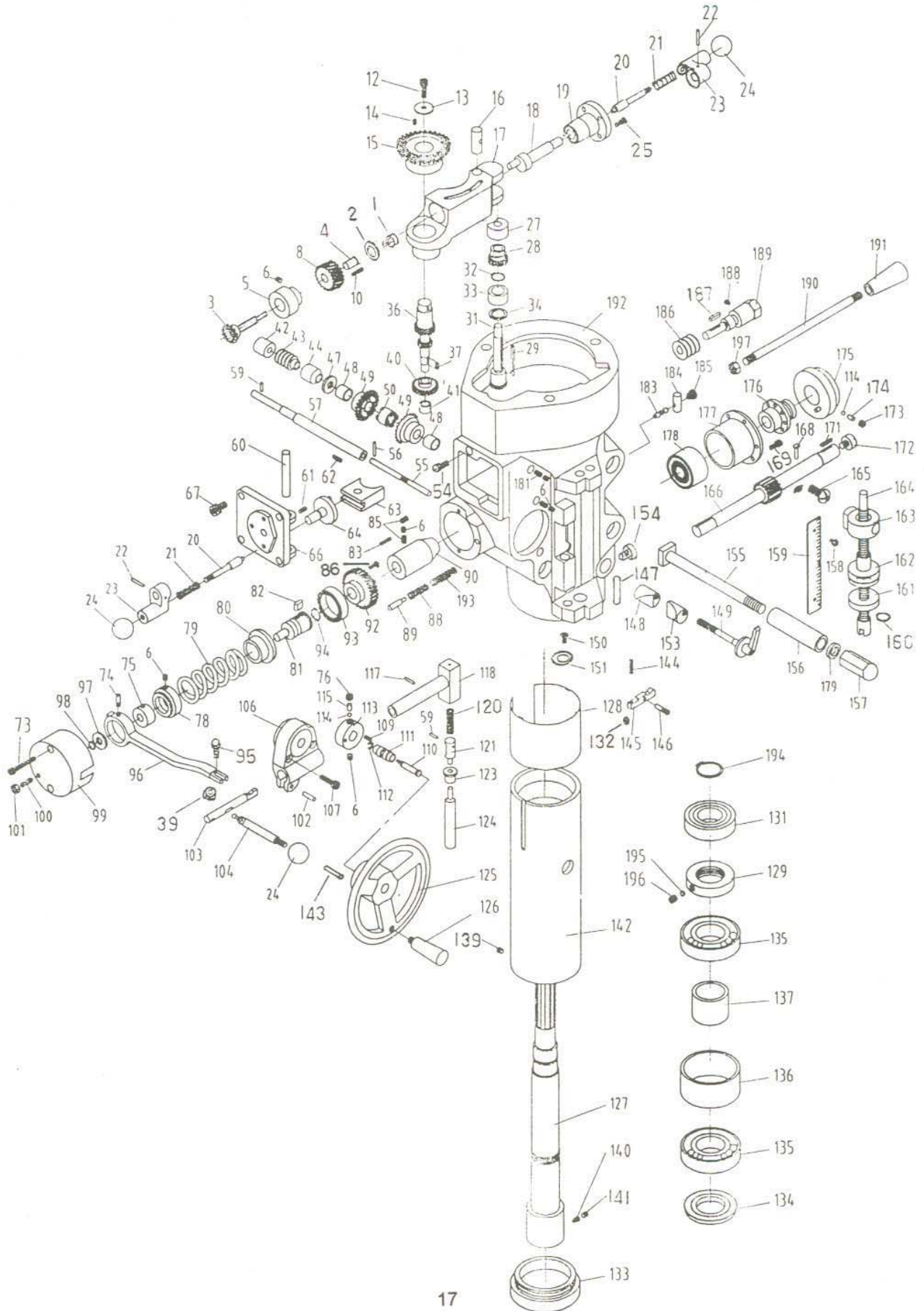

### Head Assembly

1	TS-1503031	Hex Socket Cap Screw	M6*12	1
2	B-2	Washer		1
3	B-3	Feed Bevel Pinion		1
4	B-4	Worm Gear Shaft Sleeve		1
5	B-5	Bushing		1
6	TS-1522011	Set Screw		1
8	B-8	Worm Gear		1
10	KEY3312	Key	3*3*12	1
12	TS-1504031	Hex Socket Cap Screw	M8*16	1
13	B-13	Washer		1
14	KEY3308	Key	3*3*8	2
15	B-15	Bevel Gear		1
16	B-16	Feed Engage Pin		1
17	B-17	Worm Gear Cradle		1
18	B-18	Worm Gear Cradle Shaft		1
19	B-19	Shaft Sleeve		1
20	B-20	Gear Shaft Plunger		2
21	B-21	Spring		2
22	B-22	Spring Pin	3*20	2
23	B-23	Shift Crank		2
24	B-24	Black Plastic Ball		3
25	TS-1503010	Hex Socket Cap Screw	M5x12	3
27	B-27	Bushing		1
28	B-28	Gear		1
29	KEY3345	Key	3*3*45	1
31	B-31	Gear Shaft		1
32	B-32	Snap Ring	S-16	1
33	B-33	Bevel Gear Bushing		1
34	B-34	Spacer		1
36	B-36	Gear		1
39	TS-1540031	Nut	M5	1
40	B-40	Feed Drive Gear		1
41	B-41	Needle Bearing		1
42	B-42	Bushing		1
43	B-43	Worm Gear		1
44	B-44	Bushing		1
47	B-47	Washer		1
48	B-48	Bushing		2
49	B-49	Bevel Gear		2
50	B-50	Feed Reverse Clutch		1
54	TS-1503061	Hex Socket Cap Screw	M6*25	1
55	B-55	Reverse Clutch Rod		1
56	B-56	Spring Pin	3*20	1
57	B-57	Feed Worm Shaft		1
58	TS-1523011	Set Screw	M6*6	1
59	B-59	Spring Pin	3*12	2
60	B-60	Chip Guards		1
61	TS-1522031	Set Screw	M5*10	1
62	KEY3315	Key	3*3*15	2
63	B-63	Feed Gear Shift Fork		1
64	B-64	Gear Shift Crank		1
66	B-66	Cluster Gear Cover		1

67	TS-1502031	Hex Socket Cap Screw	M5*12	4
73	TS-1502081	Hex Socket Cap Screw	M5*35	2
74	B-74	Clutch Ring Pin		2
75	B-75	Clutch Ring		1
76	TS-1523021	Set Screw	M6*8	1
78	B-78	Clutch Locknut		1
79	B-79	Safety Clutch Locknut		1
80	B-80	Overload Clutch		1
81	B-81	Overload Clutch Sleeve		1
82	KEY5813	Key	5*8*13	1
83	B-83	Hex Socket Head Bolt		3
85	TS-1523011	Set Screw	M6*6	2
86	B-86	Cross Plate Screw	M4*16	4
88	B-88	Spring		1
89	B-89	Spring Plunger		1
90	B-90	Bushing		1
92	B-92	Worm Gear		1
93	B-93	Clutch Ring		1
94	B-94	Snap Ring	S-10	1
95	TS-1502051	Hex Socket Cap Screw	M5*20	1
96	B-96	Clutch Trip Lever		1
97	B-97	Clutch Washer		1
98	B-98	Snap Ring	S-10	1
99	B-99	Clutch Arm Cover		1
100	C-19-1	Set Screw	M6*16	1
101	TS-1540041	Nut	M6	1
102	B-102	Spring Pin	5*18	1
103	B-103	Cam Rod		1
104	B-104	Trip Handle		1
106	B-106	Feed Trip Bracket		1
107	TS-1503051	Hex Socket Cap Screw	M6*20	1
108	TS-1523031	Set Screw	M6*10	1
109	KEY3310	Key	3*3*10	1
110	B-110	Knob Stud		1
111	B-111	Reverse Knob		1
112	B-112	E-Ring	E-6	1
113	B-113	Handle Wheel Clutch		1
114	B-114	Steel Ball	3/16"	2
115	B-115	Compression Spring		2
116	B-116	Set Screw	M8*6	1
117	B-117	Spring Pin	3*15	1
118	B-118	Cam Rod Sleeve		1
119	B-119	Spring Pin	3*12	1
120	B-120	Compression Spring		1
121	B-121	Trip Plunger		1
123	B-123	Bushing		4
124	B-124	Feed Trip Plunger		1
125	B-125	Handle Wheel		1
126	B-126	Handle		1
127	B-127	Spindle		1
128	B-128	Quill Skirt		1
129	B-129	Locknut		1
131	BB-6206ZZ	Ball Bearing	6206ZZ	1

132	B-132	Nut	M4	1
133	B-133	Nose Piece		1
134	B-134	Spindle Dirt Shield		1
135	BB-7207C	Angular Bearing	7207	1
136	B-136	Spacer		1
137	B-137	Spacer		1
138	BB-7207C	Angular Bearing	7207	1
139	B-139	Set Screw		1
140	B-140	Set Screw		1
141	TS-1523011	Set Screw	M6*6	1
142	B-142	Quill		1
143	B-143	Spring Pin	3*16	1
144	B-144	Set Screw	M4*20	1
145	B-145	Feed Trip Lever		1
146	B-146	Trip Lever Pin		1
147	B-147	Indicator Rod		1
148	B-148	Quill Lock Sleeve		1
149	B-149	Lock Handle		1
150	B-150	Round Head Screw	M5*8	2
151	B-151	Washer	M5	2
153	B-153	Quill Lock Sleeve		1
154	B-154	Indicator Rod Screw		1
155	B-155	T-Bolt		4
156	B-156	Spacer		4
157	B-157	Adaptor Nut		4
158	B-158	Round Head Screw		2
159	B-159	Micrometer Scale		1
160	B-160	Snap Ring	S-16	1
161	B-161	Quill Micro-Stop Nut		1
162	B-162	Quill Micro-Stop Nut		1
163	B-163	Quill Stop Knob		1
164	B-164	Quill Micro-Stop Nut		1
165	B-165	Round Head Screw	M10*15	1
166	B-166	Quill Pinion Shaft		1
168	B-168	Pin		1
169	TS-1503010	Hex Socket Cap Screw	M5*12	2
171	KEY3320	Key	3*3*20	1
172	B-172	Pinion Shaft Hub Screw		1
173	B-173	Set Screw	5/16"*1/4"	1
174	B-174	Compression Spring		1
175	B-175	Handle Hub		1
176	B-176	Hub Sleeve		1
177	B-177	Spring Cover		1
178	B-178	Clock Spring		1
179	B-179	Washer		4
181	TS-1523041	Set Screw	M6*12	2
183	B-183	Reverse Trip Ball Lever		1
184	B-184	Reverse Trip Plunger		1
185	B-185	Trip Ball Lever Screw		1
186	B-186	Worm Gear		1
187	KEY4418	Key	4*4*18	1
188	B-188	Set Screw		1
189	B-189	Worm Shaft		1
190	B-190	Pinion Shaft Hub Handle		1

191	B-191	Black Plastic Ball	1
192	B-192	Quill Housing	1
193	B-193	Compression Spring	1
194	B-194	Snap Ring	S-30 1
195	B-195	Bush	1
196	TS-1523011	Set Screw	M6*6 1
197	B-197	Nut	1

# Base Assembly

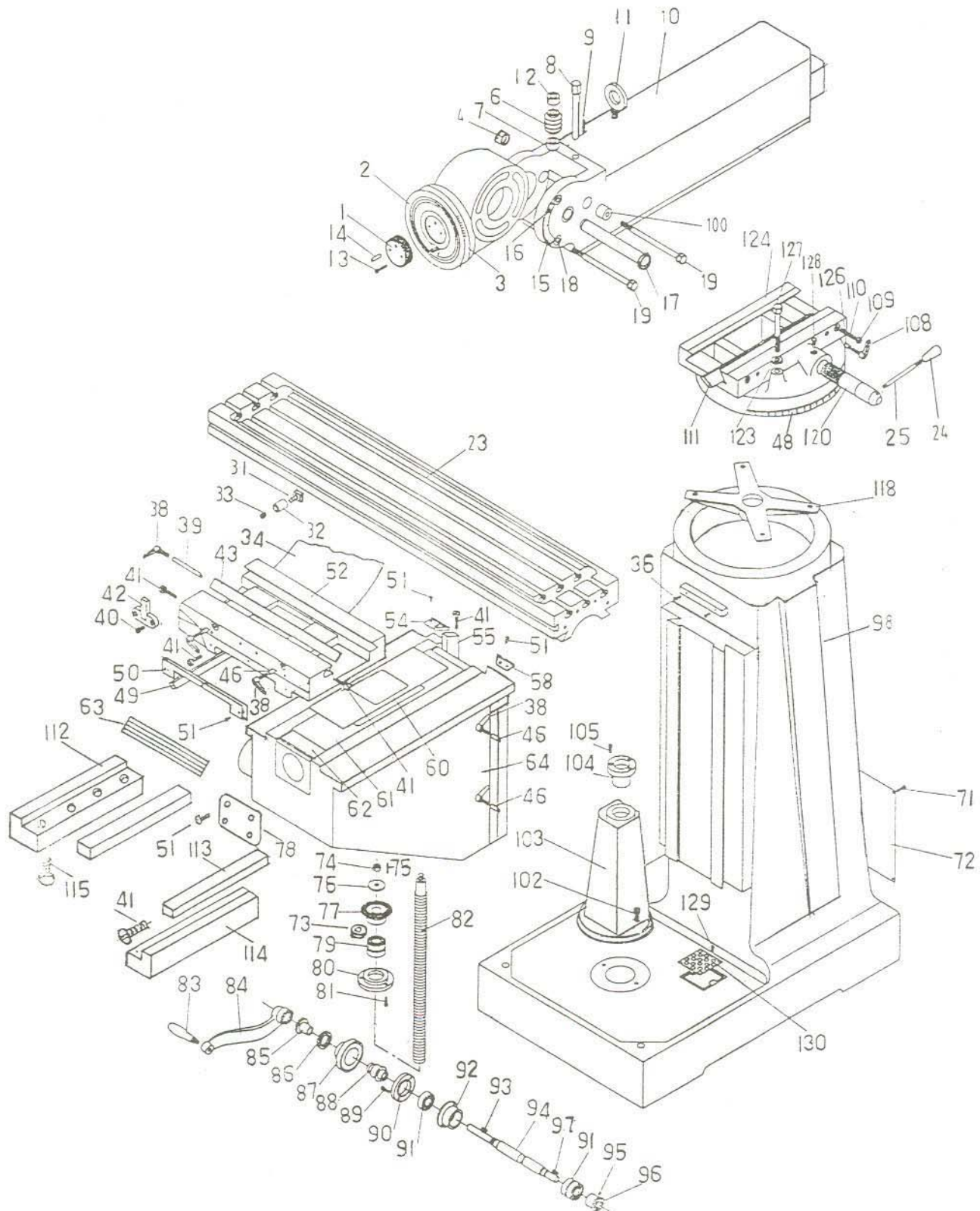

### Base Assembly

1	C-1	Worm Washer		1
2	C-2	Ram Adaptor		1
3	C-3	Adaptor Scale		1
4	C-4	Lock Nut		1
6	C-6	Worm Gear		1
7	C-12	Collar		1
8	C-8	Worm Shaft		1
9	KEY5550	Key	5*5*50	1
10	C-10	Ram		1
11	C-11	Hook	3/4"	1
12	C-7-1	Washer		1
13	TS-1504061	Hex Socket Cap Screw	M8*30	2
14	C-14	Spring Pin		1
15	C-15	Angle Plate		1
16	C-16	Rivet		10
17	C-17	Adaptor Pivot Stud		1
18	C-18	Washer		3
19	C-19	Locking Bolt		3
23	C-23	Table		1
31	C-31	T-Bolt		2
32	C-32	Table Stop Piece		2
33	C-33	Hex Nut	3/8"-16NC	2
34	C-34	Chip Guard		1
36	C-36	Pan Head Screw	3/16"*3/8"	4
38	C-38A	Saddle Lock Bolt		5
39	C-39	Saddle Lock Plunger		1
40	C-40	Hex Socket Cap Screw		2
41	C-41	Adjusting Screw		10
42	C-42	Table Stop Bracket		1
43	C-43	Gib		1
46	C-46	Table Lock Plunger		4
49	C-49	Saddle Knee Gib		1
50	C-50-1	Wiper		2
51	C-51	Pan Head Screw		18
52	C-52	Saddle		1
54	C-54	Knee Wiper Felt		1
55	C-55	Knee Column Gib		1
58	C-58	Knee Wiper Felt		1
60	C-60	Chip Guards		1
61	C-61	Chip Guards		1
62	C-62	Chip Guards		1
63	C-63	Chip Guards		1
64	C-64	Knee		1
71	C-71	Pan Head Screw		8
72	C-72	Cover		1
73	C-23-1	Washer		1
74	C-74	Nut	1/2"-20NF	1
75	KEY5525	Key	5*5*25	1
76	C-76	Washer		1
77	C-77	Bevel Gear		1
78	C-78	Front Cover		1
79	BB-5305ZZ	Ball Bearing	5305	1



80	C-80	Bearing Stop		1
81	TS-1503051	Hex Socket Cap Screw	M6*20	3
82	C-82	Leadscrew		1
83	C-83	Handle		1
84	C-84	Elevating Crank		1
85	C-85	Gear Shear Clutch		1
86	C-86	Dial Lock Nut		1
87	C-87	Dial		1
88	C-88	Dial Holder		1
89	TS-1503051	Hex Socket Cap Screw	M6*20	3
90	C-90	Bearing Stop		1
91	BB-6204ZZ	Ball Bearing	6204ZZ	2
92	C-92	Bearing Stop		1
93	KEY3318	Key	3*3*18	1
94	C-94	Shaft		1
95	C-95	Grub Set Screw		1
96	C-96	Bevel Gear		1
97	KEY4418	Key	4*4*18	1
98	C-98	Column		1
100	C-19-1	Collar		1
102	TS-1505051	Hex Socket Cap Screw	M10*35	2
103	C-103	Lead Screw Housing		1
104	C-82-1	Lead Screw Nut		1
105	TS-1503051	Hex Socket Cap Screw	M6*20	3
108	C-38A	Lock Bolt		2
109	C-109	Nut	3/8"	2
110	C-110	Set Screw		2
111	C-111	Gib		1
112	C-112	Gib Holder(L)		1
113	C-113	Gib		1
114	C-114	Gib Holder(R)		1
115	TS-1505051	Hex Socket Cap Screw	M10*35	8
118	C-118	Spider		1
120	C-120	Ram Pinion		1
123	C-123	Spring Washer		4
124	C-124	Turret		1
126	C-126	Ram Lock Plunger		2
127	C-127	Locking Bolt		4
128	C-128	Ram Pinion Set Screw		1
129	C-129	Rivet		2
130	C-130	Strainer		1
131	JM-1050	Stripe Decal (Not Shown)		1

# Leadscrew Assembly

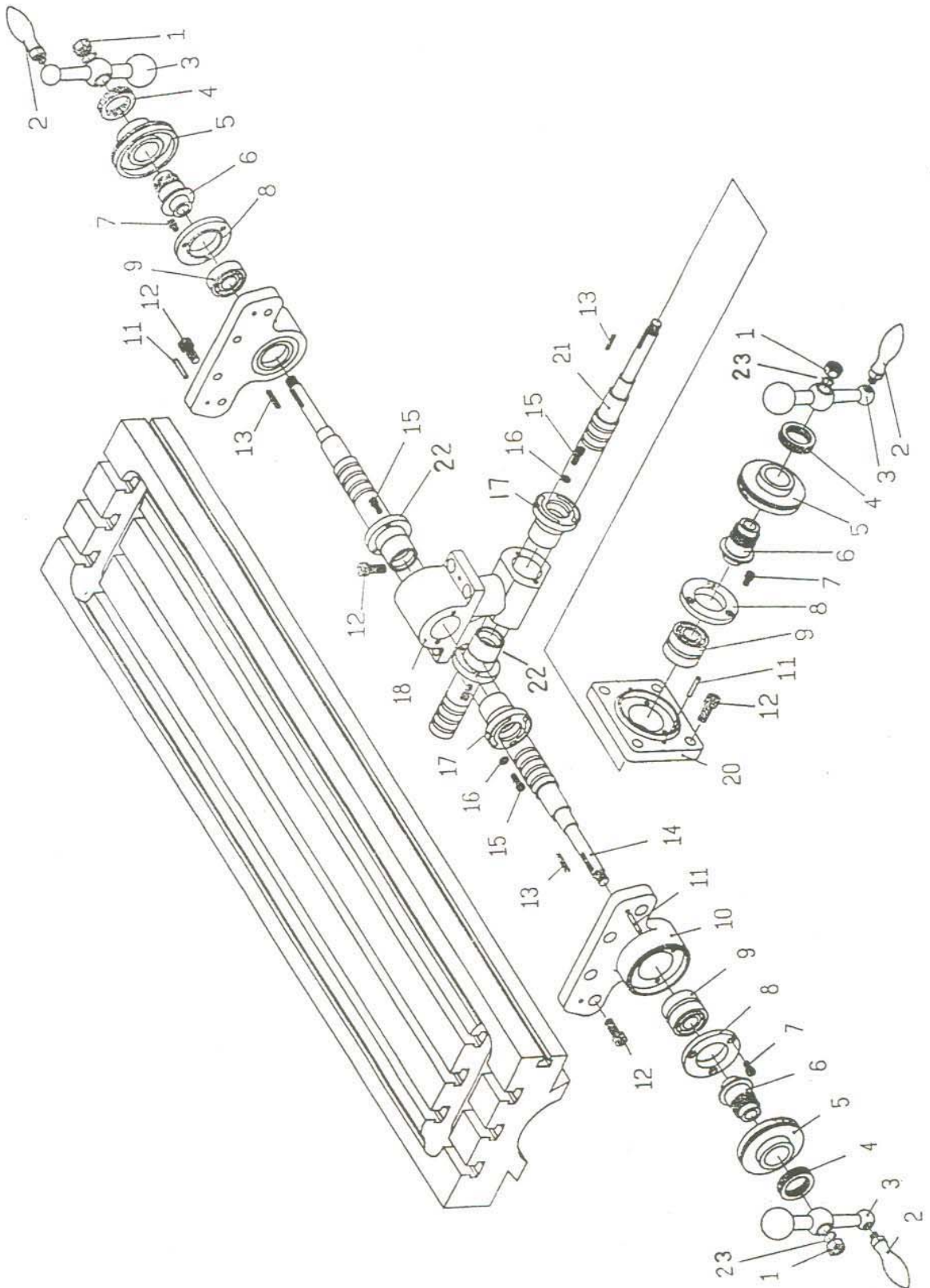

### Leadscrew Assembly

1	D-1	Nut	1/2"-20NF	3
2	D-2	Handle		3
3	D-3	Ball Crank		3
4	D-4	Dial Lock Nut		3
5	D-5	Dial		3
6	D-6	Dial Holder		3
7	TS-1503031	Hex Socket Cap Screw	M6*12	9
8	C-90	Bearing Stop		3
9	BB-6204ZZ	Ball Bearing	6204ZZ	5
10	D-10	Bearing Bracket		2
11	D-11	Spring Pin	5*25	6
12	TS-1505031	Hex Socket Cap Screw		16
13	KEY3325	Key	3*3*25	3
14	D-14	Leadscrew		1
15	TS-1503061	Hex Socket Cap Screw		10
16	H-9	Washer		4
17	D-17	Feed Screw Nut		2
18	D-18	Feed Nut Bracket		1
20	D-20	Cross Bearing Bracket		1
21	D-21	Cross Feed Screw		1
22	D-22	Cross Feed Nut		2
23	D-23	Spring Washer	1/2"	3

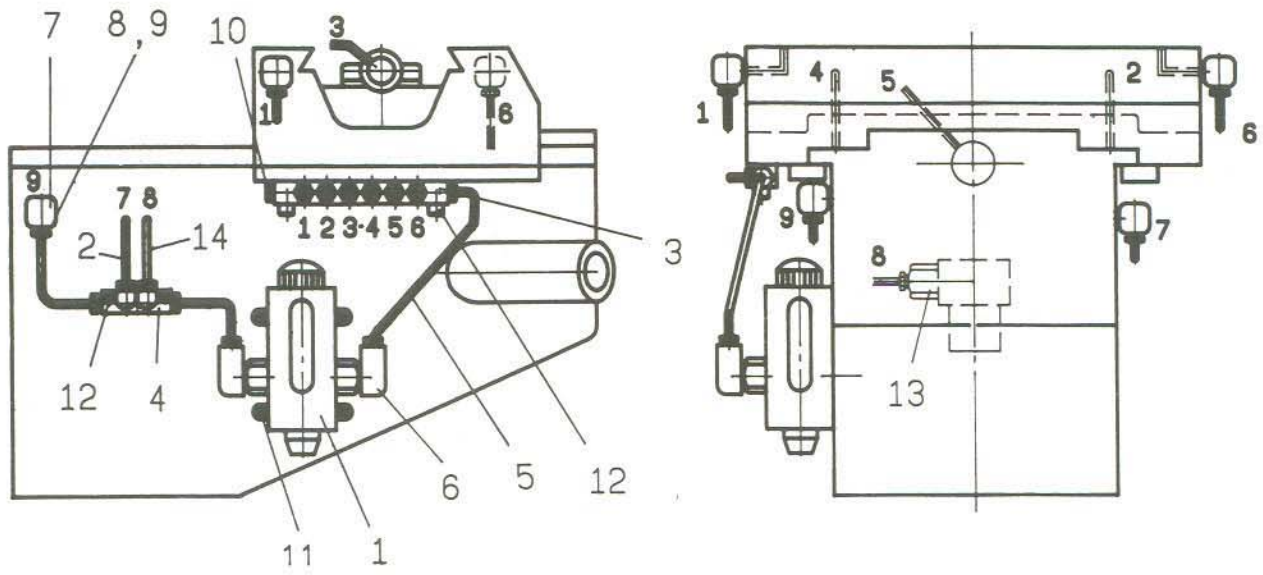

### One Shot Lubrication System

1	.....	CLA-8	Handle Oiler.....	1
2	.....	ALMP-04	Aluminum Piece..... 13.5mm	1
3	.....	A-8	Oil Regulation Distributor.....	1
4	.....	A-4	Oil Regulation Distributor.....	1
5	.....	A-5	Flexible Steel Tube..... 4*550	1
6	.....	PH-4011	Elbow Joint.....	2
7	.....	PI-401	Elbow Joint.....	6
8	.....	PA-4	Thimble Nut.....	20
9	.....	PB-4	Thimble.....	20
10	.....	PG-004	Union.....	1
11	.....	JTM4VS-BUTW1458	Screw..... M6*14	4
12	.....	TS-1502061	Hex Socket Cap Screw..... M5*25	4
13	.....	PD-401	Straight Joint.....	1
14	.....	A-14	Nylon Piece..... 4*700	1

# Electrical Schematic

For 230 V

For 460 V

