

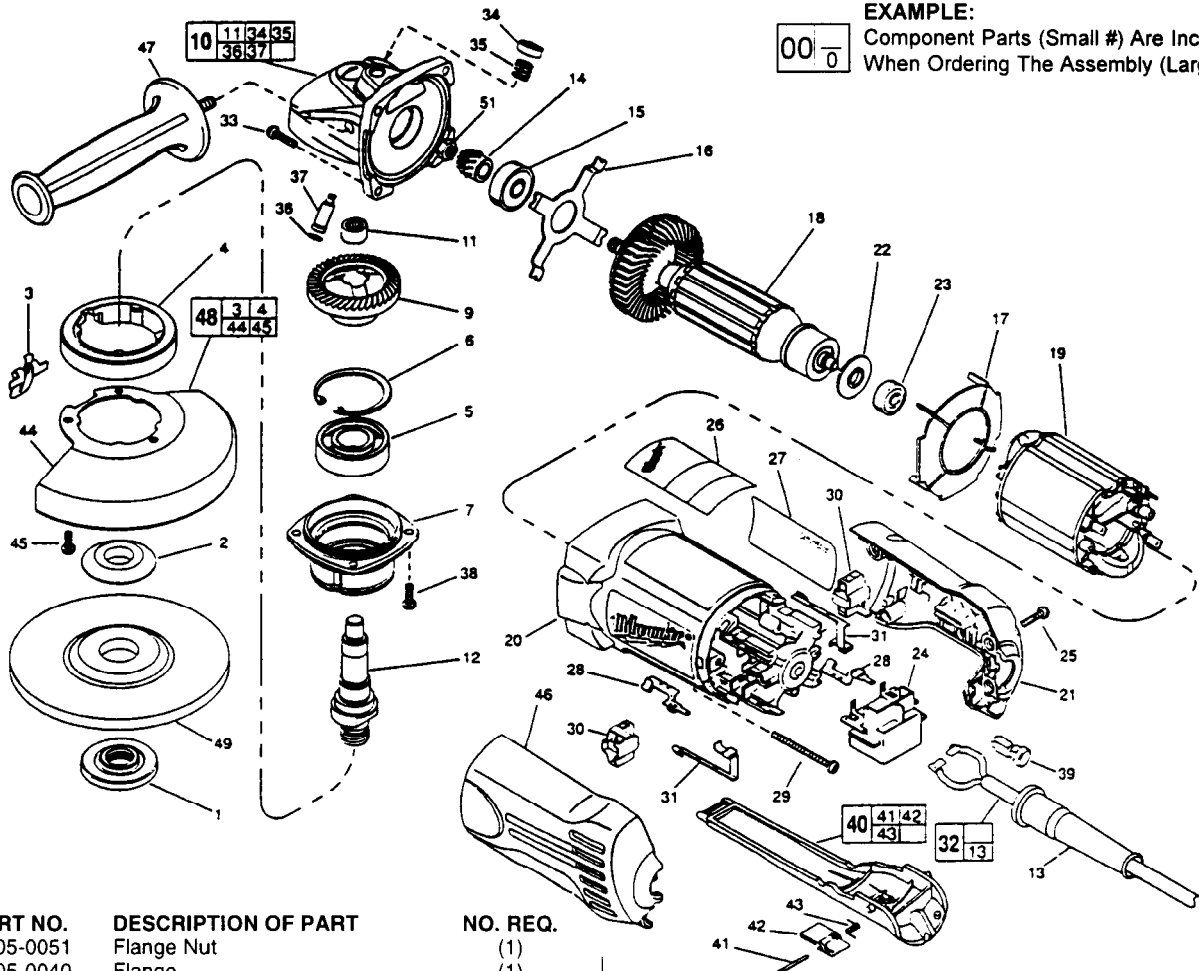

SERVICE PARTS LIST

BULLETIN NO.
54-38-1250

SPECIFY CATALOG NO. AND SERIAL NO. WHEN ORDERING PARTS		REVISED BULLETIN	DATE
5" ANGLE GRINDER			Aug. '98
CATALOG NO. 6152-02	STARTING SERIAL NUMBER	920A	
		WIRING INSTRUCTION	



EXAMPLE:

00	0
----	---

 Component Parts (Small #) Are Included When Ordering The Assembly (Large #).

FIG.	PART NO.	DESCRIPTION OF PART	NO. REQ.
1	49-05-0051	Flange Nut	(1)
2	49-05-0040	Flange	(1)
3	44-20-0325	Lock Lever	(1)
4	45-36-1551	Spacer	(1)
5	02-04-1745	Ball Bearing	(1)
6	34-80-2960	Retaining Ring - Internal	(1)
7	28-52-0222	Spindle Hub	(1)
9	32-05-1310	P.M. Gear	(1)
10	25-14-2350	Gear Case Assembly	(1)
11	02-50-2423	Needle Bearing	(1)
12	38-50-5202	Spindle	(1)
13	44-76-0210	Cord Protector	(1)
14	32-60-1310	Pinion Gear	(1)
15	02-04-2075	Ball Bearing	(1)
16	44-66-5345	Bearing Retainer Plate	(1)
17	42-14-0400	Baffle	(1)
18	16-07-0126	Armature	(1)
19	18-07-0125	Field	(1)
20	31-50-1100	Motor Housing	(1)
21	31-15-0450	Right Cover	(1)
22	23-16-0916	Commutator Insulator	(1)
23	02-04-2080	Ball Bearing	(1)
24	23-66-2401	Switch	(1)
25	06-82-7271	6-19 x 7/8" Pan Hd. Plastite T-15	(4)
26	12-20-6193	Service Nameplate Kit	(1)
27	10-98-7090	Warning Label	(1)
28	23-74-1206	Brush Terminal	(2)
29	06-82-7420	6-19 x 2-3/4" Pan Hd. Slit. Plast. T-15	(2)
30	22-20-0555	Brush Holder Assy. (Incl. Carbon Brush)	(2)
31	23-74-1201	Switch Terminal	(2)
32	22-64-0840	Cord Set Assembly	(1)
33	06-82-7326	8-16 x 1" Pan Hd. Slit. Plast. T-20	(4)
34	31-12-0205	Cap	(1)
35	40-50-8650	Compression Spring	(1)

FIG.	PART NO.	DESCRIPTION OF PART	NO. REQ.
36	34-40-4300	O-Ring	(1)
37	44-60-0845	Lock Pin	(1)
38	06-82-5316	8-32 x 1/2" Pan Hd. Slit. Tapt. T-20	(4)
39	31-53-0112	Plug	(1)
40	31-92-0320	Paddle Assembly	(1)
41	06-65-1915	Pin	(1)
42	42-42-0390	Lock-Off Button	(1)
43	40-50-8750	Torsion Spring	(1)
44	28-41-1025	Hood	(1)
45	06-82-7251	8-16 x 3/8" Pan Hd. Slit. Plast. T-20	(3)
46	31-15-0455	Left Cover	(1)
47	49-15-0310	Side Handle	(1)
48	49-12-0366	Guard Assembly	(1)
49	-----	5" Disc - Select From Catalog	(1)
51	06-55-3850	10-32 Hex Nut	(1)
	49-96-7205	Spanner Wrench	(1)

FIG. LUBRICATION:
 9,14 Type "O" Grease, No. 49-08-4200, Must Be Applied To All Gear Teeth.
 10 18-21 Grams Type "O" Grease, No. 49-08-4200.

FIG. NOTES:
 7 Position The Spindle Hub With The Side That Has The Word "Back" Orientated Toward The Rear Of The Tool.
 11 Press .09" Below Casting Surface.
 32 Tuck All Cord Leads Away From Vent Openings.
 51 Torque To 25-35 In./Lbs.