



# SERVICE PARTS LIST

**BULLETIN NO.**  
**54-38-1125**

SPECIFY CATALOG NO. AND SERIAL NO. WHEN ORDERING PARTS		REVISED BULLETIN	DATE
<b>6" RANDOM ORBIT SANDER</b>			July '96
CATALOG NO.	6020-02	SERIAL NUMBER	904A
		WIRING INSTRUCTION <b>58-01-1175</b>	

EXAMPLE:  
00 0

Component Parts (Small #) Are Included  
When Ordering The Assembly (Large #).

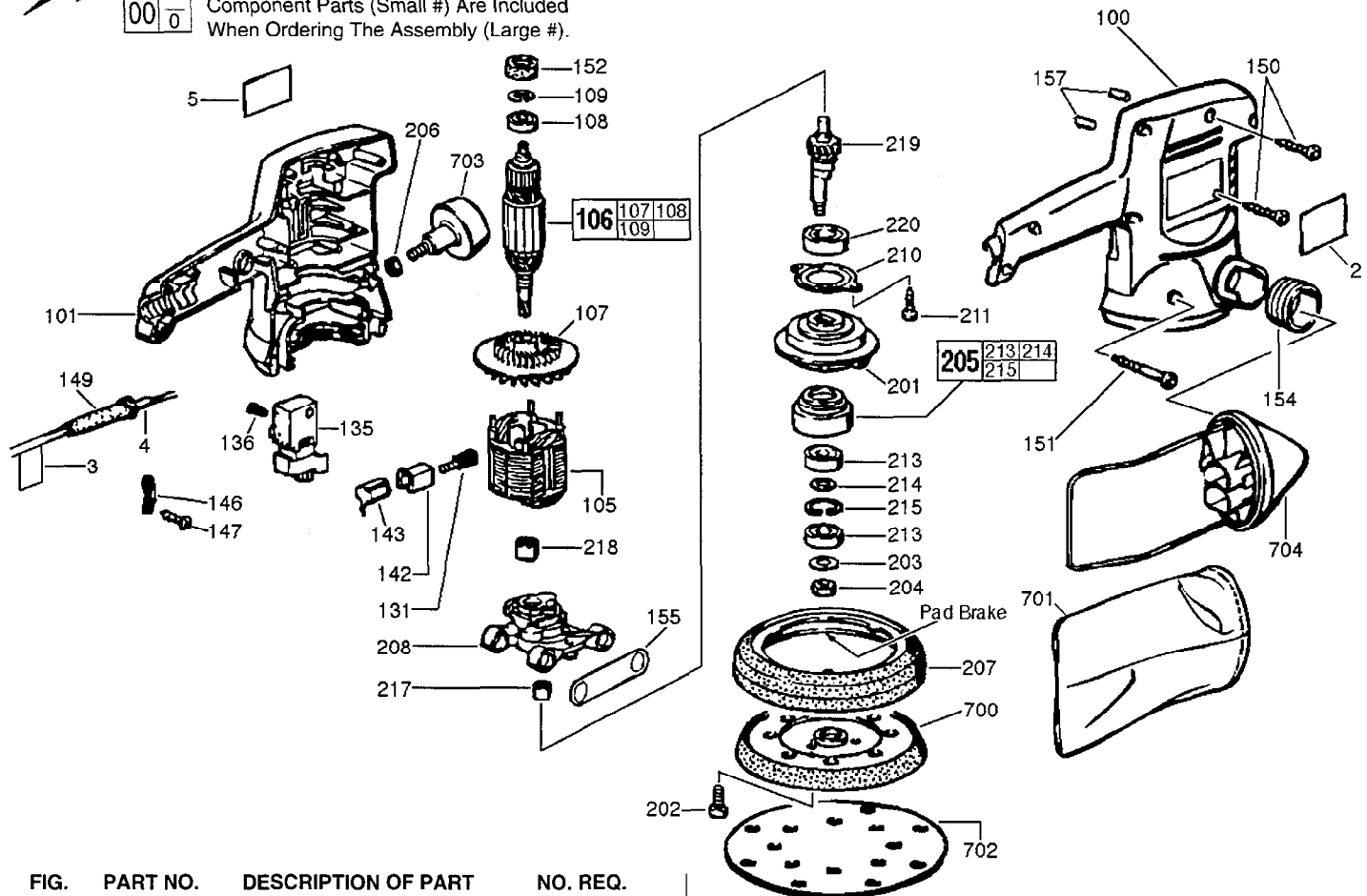

FIG.	PART NO.	DESCRIPTION OF PART	NO. REQ.
2	10-15-1145	Logo Label	1
3	10-98-1205	Cord Tag	1
4	22-64-0525	Cord	1
5	12-20-6020	Service Nameplate	1
100	31-50-1015	Right Motor Housing	1
101	31-50-1016	Left Motor Housing	1
105	18-07-0128	Field	1
106	16-07-0128	Armature	1
107	22-84-0925	Fan	1
108	02-04-0830	Ball Bearing	1
109	44-90-0340	Snap Ring (Ext.)	1
131	22-16-0285	Carbon Brush	2
135	23-66-0295	Switch	1
136	05-81-0940	Screw	2
142	22-20-0225	Brush Holder	2
143	22-20-0645	Brush Tube	2
146	31-17-0240	Cord Clamp	1
147	05-81-0930	Screw	2
149	44-76-0280	Strain Relief	1
150	05-88-9601	Screw	8
151	05-81-0425	Screw	2
152	45-22-0575	Rubber Sleeve	1
154	44-90-0025	Dust Chute Ring	1
155	44-66-6145	Shim Plate	2
157	45-30-0205	Vinyl Slug	2
201	42-88-0110	Counterweight	1
202	05-81-0445	Screw	3
203	45-88-8335	Thrust Washer	1
204	05-55-0045	Nut	1
205	28-53-0225	Hub	1
206	05-55-0065	Nut	1

FIG.	PART NO.	DESCRIPTION OF PART	NO. REQ.
207	44-90-0030	Dust Shroud	1
208	43-76-0485	Gear Housing Assembly	1
210	42-92-0940	Bearing Retainer Plate	1
211	05-81-0985	Screw	2
213	02-04-1825	Ball Bearing	2
214	45-88-7410	Thrust Washer	1
215	45-88-0790	Locking Washer	1
217	02-50-2030	Needle Bearing	1
218	45-22-0225	Sleeve	1
219	38-50-5025	Spindle	1
220	02-04-0835	Ball Bearing	1
700	49-36-7002	6" Sanding Pad	1
701	48-09-1035	Dust Bag	1
702	-----	Sanding Pad	1
703	43-98-0055	Front Knob	1
704	42-16-0545	Dust Bag Adapter	1
	23-94-1155	Wire Assembly (Not Shown)	1
	23-94-1160	Wire Assembly (Not Shown)	1

**FIG. LUBRICATION:**  
207 Coat Bottom And Inside Of Pad Brake With Type "L" Grease, No. 49-08-4170.  
208 Place 0.1 Oz. Of Type "E" Grease, No. 49-08-4122, In Gearcase.

**FIG. NOTE:**  
150 One Screw Is Located Under Logo Label.

**MILWAUKEE ELECTRIC TOOL CORPORATION**  
13135 W. LISBON RD., BROOKFIELD, WI 53005