



# SERVICE PARTS LIST

**BULLETIN NO.**  
**55-24-3800**

SPECIFY CATALOG NO. AND SERIAL NO. WHEN ORDERING PARTS		REVISED BULLETIN	DATE
<b>3/8" PISTOL HAMMER DRILL</b>			Feb. '97
CATALOG NO. <b>5392-55</b>	STARTING SERIAL NO. <b>665A</b>	WIRING INSTRUCTION <b>58-03-1405</b>	

**EXAMPLE:**  
Component Parts (Small #) Are Included  
When Ordering The Assembly (Large #).

00  
0

FIG.	PART NO.	DESCRIPTION OF PART	NO. REQ.
	38	02-02-0180 3/16" Steel Ball	(6)
	39	44-84-0240 Fixed Ratchet	(1)

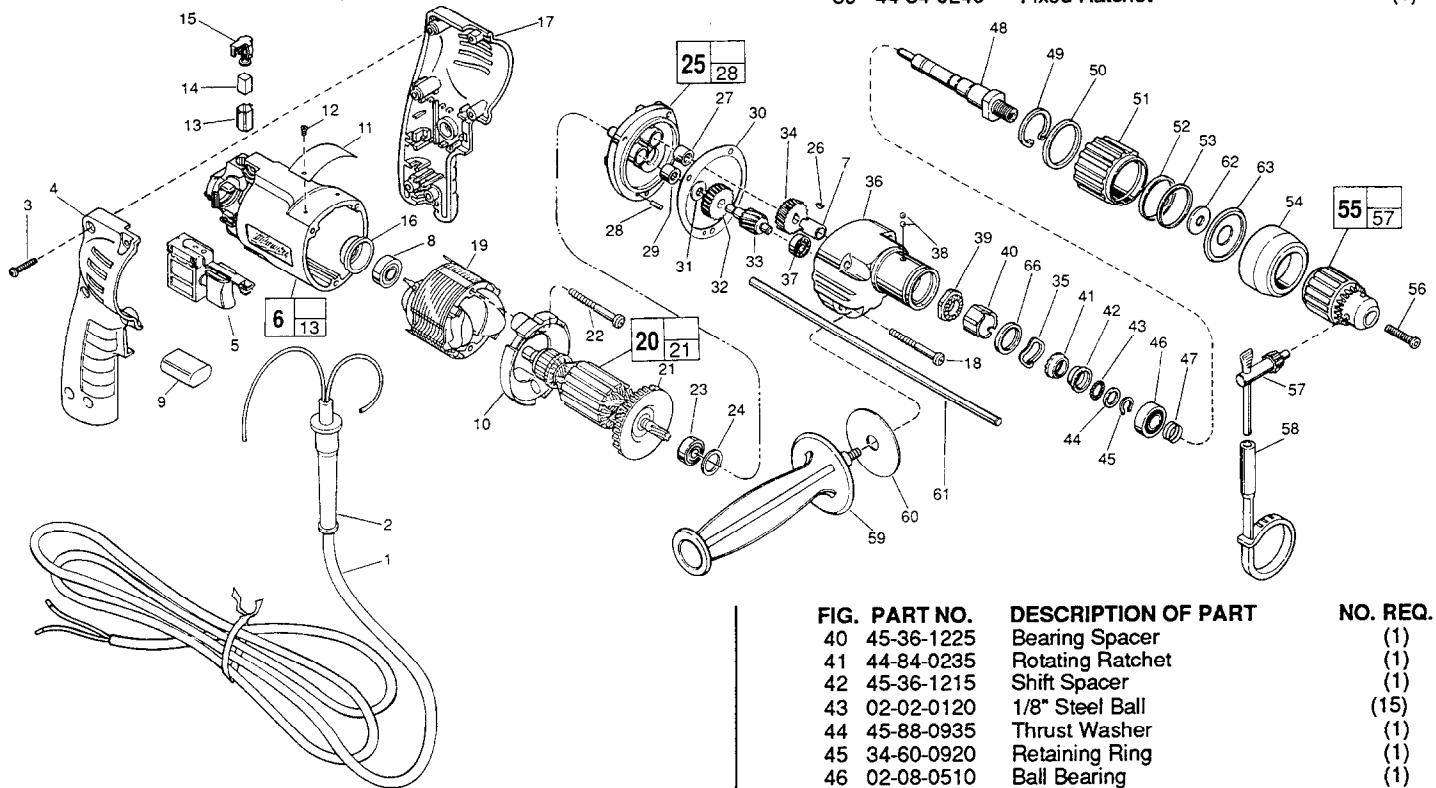

FIG.	PART NO.	DESCRIPTION OF PART	NO. REQ.
1	22-64-4485	Cord Set	(1)
2	44-76-0210	Cord Protector	(1)
3	06-82-7284	8-16 x 3/4" Pan Hd. Slit. Plast. T-20	(6)
4	31-44-1745	Right Handle Half	(1)
5	23-66-2146	Speed Control Switch	(1)
6	14-38-0591	Motor Housing Assembly	(1)
7	45-36-1260	Gear Spacer	(1)
8	02-04-0645	Ball Bearing	(1)
9	14-20-0530	Capacitor Assembly	(1)
10	42-14-0380	Baffle	(1)
11	12-99-1011	Nameplate Blank	(1)
12	06-72-1720	Nameplate Rivet	(2)
13	22-20-0830	Brush Tube	(2)
14	22-16-0275	Carbon Brush	(2)
15	23-52-1560	Brush Spring Assembly	(2)
16	22-72-0100	Bearing Cup	(1)
17	31-44-1740	Left Handle Half	(1)
18	06-82-7393	7-18 x 2" Pan Hd. Slit. Plastite T-20	(1)
19	18-11-0150	120 Volt Field	(1)
20	16-10-0680	120 Volt Armature	(1)
21	22-84-0880	Fan Assembly	(1)
22	06-82-7203	7-18 x 2-1/8" Pan Hd. Slit. Plast. T-20	(2)
23	02-04-0848	Ball Bearing	(1)
24	45-88-0355	Fiber Washer	(1)
25	14-13-0540	Diaphragm Assembly	(1)
26	06-42-0400	Woodruff Key	(1)
27	02-50-1611	Needle Bearing	(1)
28	06-65-0880	Ground Pin	(1)
29	02-50-1640	Needle Bearing	(1)
30	43-44-0900	Gasket	(1)
31	45-88-7721	Thrust Washer	(1)
32	32-40-1940	Intermediate Gear	(1)
33	36-66-4360	Intermediate Pinion Shaft	(1)
34	32-75-3175	Spindle Gear	(1)
35	45-88-0940	Overlap Wave Washer	(1)
36	28-14-2105	Gear Case	(1)
37	02-04-0640	Ball Bearing	(1)

FIG.	PART NO.	DESCRIPTION OF PART	NO. REQ.
40	45-36-1225	Bearing Spacer	(1)
41	44-84-0235	Rotating Ratchet	(1)
42	45-36-1215	Shift Spacer	(1)
43	02-02-0120	1/8" Steel Ball	(15)
44	45-88-0935	Thrust Washer	(1)
45	34-60-0920	Retaining Ring	(1)
46	02-08-0510	Ball Bearing	(1)
47	40-50-0220	Compression Spring	(1)
48	38-50-5515	Spindle	(1)
49	34-80-2020	Internal Retaining Ring	(1)
50	34-40-4040	O-Ring	(1)
51	31-58-0055	Locking Collar	(1)
52	34-40-1500	O-Ring	(1)
53	34-60-2125	Retaining Ring	(1)
54	49-62-0090	Hammer Dust Shield	(1)
55	48-66-0795	3/8" Chuck	(1)
56	45-04-0755	Chuck Screw	(1)
57	48-66-3240	Chuck Key	(1)
58	48-66-4040	Key Holder	(1)
59	43-62-0905	Side Handle	(1)
60	45-88-7930	Washer	(1)
61	44-94-0161	Depth Rod	(1)
62	45-88-1040	Washer	(1)
63	44-86-0510	Retainer	(1)
64	14-20-0750	Remote Electronic Assembly	(1)
65	06-82-7212	4-20 x 1/4" Pan Hd. Plast. T-10	(1)
66	45-36-1255	Flanged Spacer	(1)

**FIG. NOTES**

23 Press flush to casting surface. Seal towards armature.  
56 Apply type 242 blue loctite and torque to 40-45 in./lbs.  
16 Place in motor housing before inserting armature.  
8 Seal towards armature.  
27, 29 Press flush to casting surface.  
27 Press only on end with manufacturer ID.  
3 Torque to 18-28 In./Lbs.  
65 Torque to 3-5 In./Lbs.  
22 Torque field screws to 15-20 In./Lbs.  
Torque gear case screws to 30-38 In./Lbs.

**FIG. LUBRICATION**

36 1-1/2 oz. type "K" grease, No. 49-08-4161.  
39, 41 1/2 tsp. type "K" grease, No. 49-08-4161.  
42, 43 1/4 tsp. type "K" grease, No. 49-08-4161.  
50, 52 Coat with type "K" grease, No. 49-08-4161.

**MILWAUKEE ELECTRIC TOOL CORPORATION**  
13135 W. LISBON RD., BROOKFIELD, WI 53005