



# SERVICE PARTS LIST

BUL. 54-00-0910

## ALTERNATOR MOUNTING BASE

REVISED BUL  DATE June '70

Catalog No. 4790

Starting Serial No. 439-1001

WIRING INSTR. 54-00-0950

Both Model and Serial No. must be furnished to obtain correct parts.

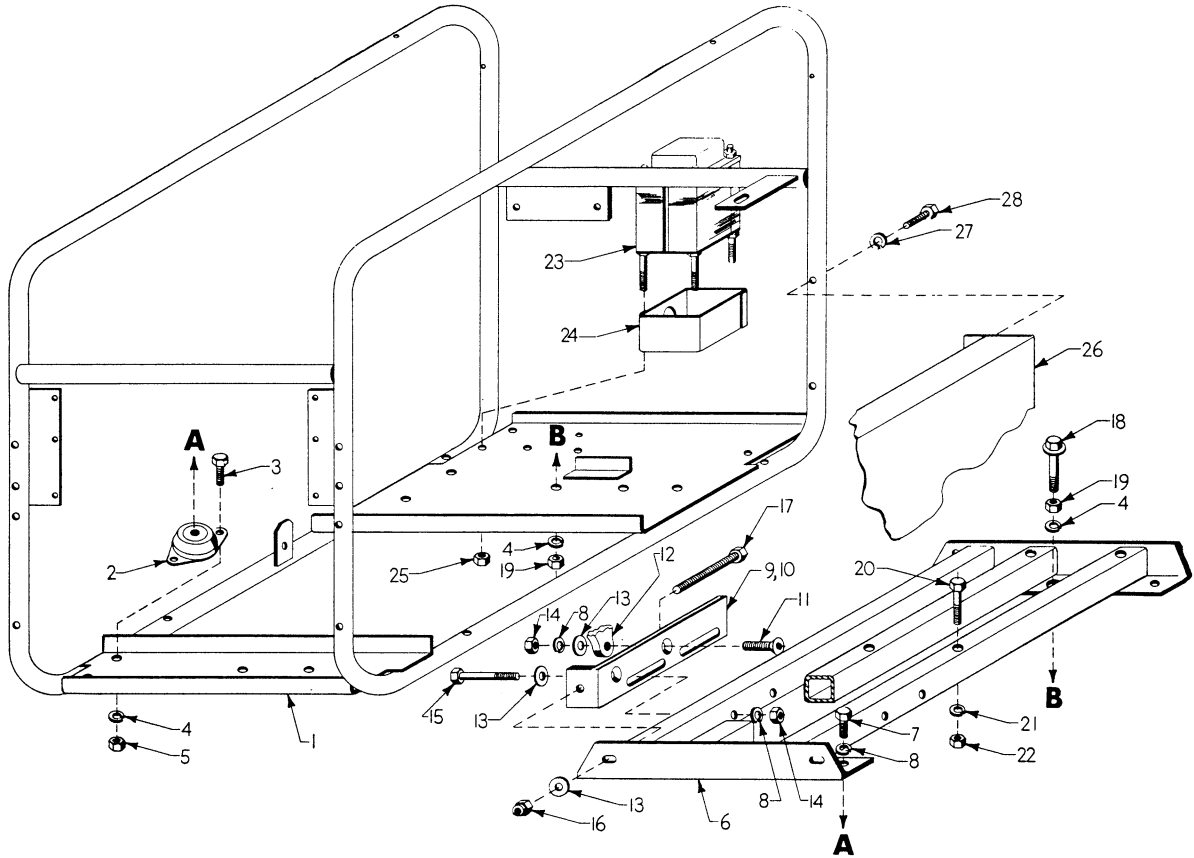

Item	Part No.	Req'd	Description
1	42-20-0360	1	Mounting Base
2	43-33-0310	4	Vibration Dampener
3	06-75-0340	8	5/16-18 x 1" Lg. Hex Hd. Capscrew
4	06-97-4100	10	5/16 Lockwasher
5	06-55-1980	8	5/16-18 Hex Nut
6	42-20-0370	1	Sub Mounting Base
7	06-75-0525	4	3/8-16 x 1 1/4 Lg. Hex Hd. Capscrew
8	06-97-4125	14	3/8 Lockwasher
9	42-05-0050	1	Belt Tensioner (R.H.) not shown
10	42-05-0100	1	Belt Tensioner (L.H.)
11	06-75-4695	4	3/8-16 1 1/4 Lg. Flat Hd. Socket Capscrew
12			ALTERNATOR
13	45-88-5261	10	3/8 Flat Washer
14	06-55-2400	8	3/8-16 Hex Nut
15	06-75-0675	4	3/8-16 x 2 1/2 Lg. Hex Hd. Capscrew
16	06-57-5160	2	3/8-16 "Greer" Hex. Nut
17	06-75-0680	2	3/8-16 x 3" Lg. "Top" Bolt
18	06-75-0305	2	Base Retainer Bolt
19	06-55-1980	4	5/16-18 Jam Hex Nut
20	06-75-0700	4	7/16-14 x 3" Lg. Hex Hd. Capscrew
21	06-97-4150	4	7/16 Lockwasher
22	06-55-2700	4	7/16-14 Hex Nut
23	23-81-0180	1	Reactor Assembly
24	22-12-0125	1	Reactor Support Box
25	06-55-1100	8	10-32 "Locknut" Hex Nut
26	43-54-0225	1	Belt Guard
27	06-97-1000	4	1/4 Lockwasher
28	06-75-0200	4	1/4-20 x 1 1/4 Lg. Hex Hd. Capscrew
29	45-60-0260	1	Reactor Support & Cover
30	06-75-2450	4	10-32 x 3/4 Lg. Rd. Hd. Mch. Screw
31	45-88-7205	4	10 Flat Washer
32	54-60-0270	1	Reactor Support



# SERVICE PARTS LIST

BUL. 54-00-0920

## ALTERNATOR CONNECTION PANEL

REVISED BUL  DATE  
Feb.'71

Catalog No. **4790**

Starting Serial No. **439-1001**

WIRING INSTR. **54-00-0950**

Both Model and Serial No. must be furnished to obtain correct parts.

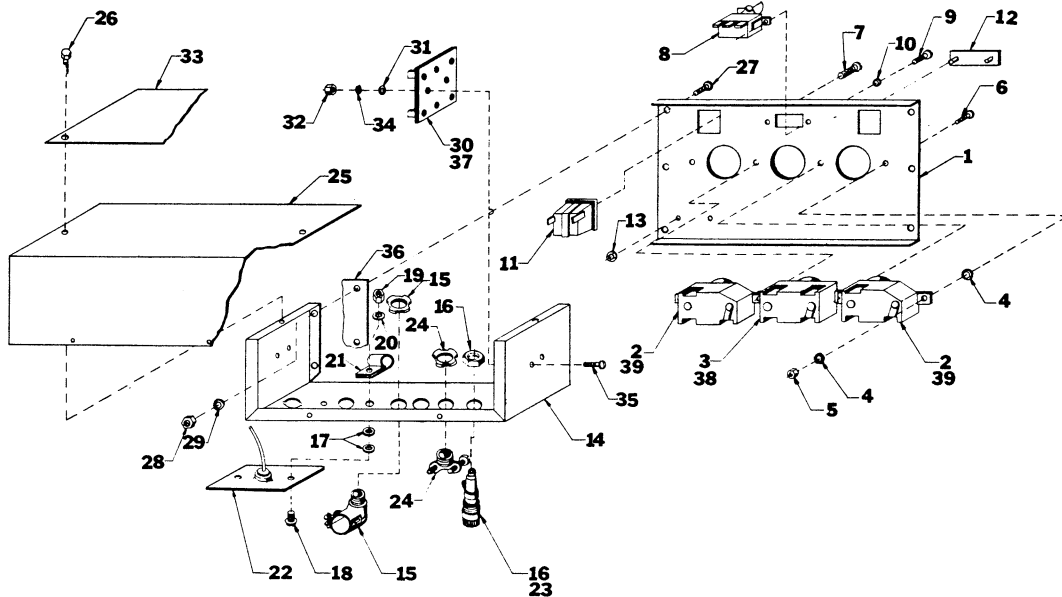

Item	Part No.	Req'd	Description
1	23-35-0110	1	Connection Panel
2	23-33-0210	2	Outlet 115V - 3 Pole "Twist Lock" 230V-4
3	23-33-0215	1	
4	06-97-0810	8	8 Shakeproof - Ext.
5	06-55-0825	4	8-32 Hex Nut
6	06-81-4566	3	8-32 x 3/8" Lg. Rd. Hd. Mch. Screw
7	06-81-3650	1	8-32 x 3/4" Lg. Rd. Hd. Mch. Screw
8	23-66-0840	1	SPDT Rocker Switch
9	06-81-0040	2	6-32 x 1/4 Lg. Pan. Hd. Mch. Screw
10	45-88-7210	2	Nylon Washer
11	23-33-0130	2	115V Outlet
12	12-02-0060	1	Name Plate
13	06-57-3010	2	Tinnerman Speed Nut
14	22-12-0130	1	Connection Panel Box
15	22-56-0260	2	Greenfield Conn.
16	23-04-0070	1	Fuse Holder
17	45-88-7050	4	10 Flat Washer
18	06-81-4568	2	8-32 x 5/8 Lg. Md.Mch. Screw
19	06-55-0825	2	8-32 Hex Nut
20	06-97-2000	2	8-32 Shakeproof - Int.
21	22-38-0110	1	L Clamp
22	44-66-5260	1	Rectifier Support Plate
23	22-89-0100	1	Fuse 30 amp (not shown)
24	22-56-0270	1	3/8 Straight Connector
25	42-92-0250	1	Cover
26	06-75-2400	4	10-32 x 1/2 Lg. Taptite Screw
27	06-81-4652	6	10-32 x 1/2 Lg. Rd. Hd. Mch. Screw
28	06-55-1100	6	10-32 Hex Nut
29	06-97-0870	6	10 Shakeproof - Ext.
30	23-04-0090	1	Fuse Holder
31	45-88-7215	2	6 Flat Washer
32	06-55-0600	2	6-32 Hex Nut
33	45-12-0270	1	Shield
34	06-97-1800	2	6 Shakeproof
35	06-81-4552	2	6-32 x 5/8 Lg. Rd. Hd. Mch. Screw
36	42-20-0380	1	Mounting Base
37	22-89-0065	2	Fuses (15 Amp) Not Shown
* 38	22-32-0300	1	Outlet Cap (Hubble 3431) Not Shown
* 39	22-32-0310	2	Outlet Cap (Hubble 3331) Not Shown

\* See Wiring Diagram for proper connection.



# SERVICE PARTS LIST

BUL. 54-00-0950

## ALTERNATOR WIRING DIAGRAM

REVISED BUL  DATE June '70

Catalog No. **4790**

Starting Serial No. **439-1001**

WIRING INSTR.

Both Model and Serial No. must be furnished to obtain correct parts.

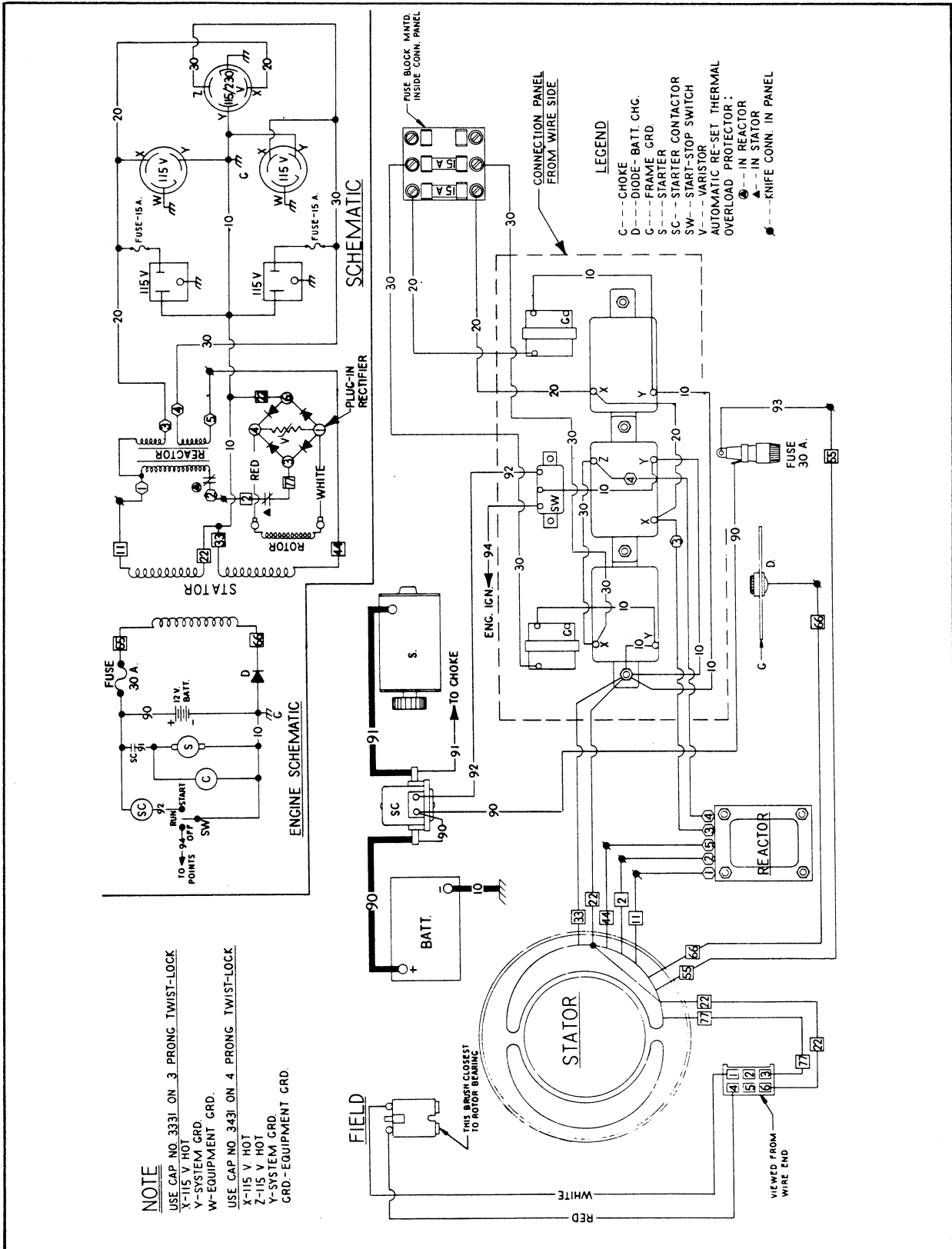

**NOTE**

- USE CAP. NO. 3331 ON 3 PRONG TWIST-LOCK
- X-115 V. HOT
- Y-SYSTEM GRD.
- W-EQUIPMENT GRD.
- USE CAP. NO. 3431 ON 4 PRONG TWIST-LOCK
- X-115 V. HOT
- Z-115 V. HOT
- Y-SYSTEM GRD.
- GRD.-EQUIPMENT GRD.



# SERVICE PARTS LIST

BUL. 54-00-0900

## 7000 WATT ALTERNATOR

REVISED BUL  DATE June '70

Catalog No. 4790

Starting Serial No. 439-1001

WIRING INSTR. 54-00-0950

Both Model and Serial No. must be furnished to obtain correct parts.

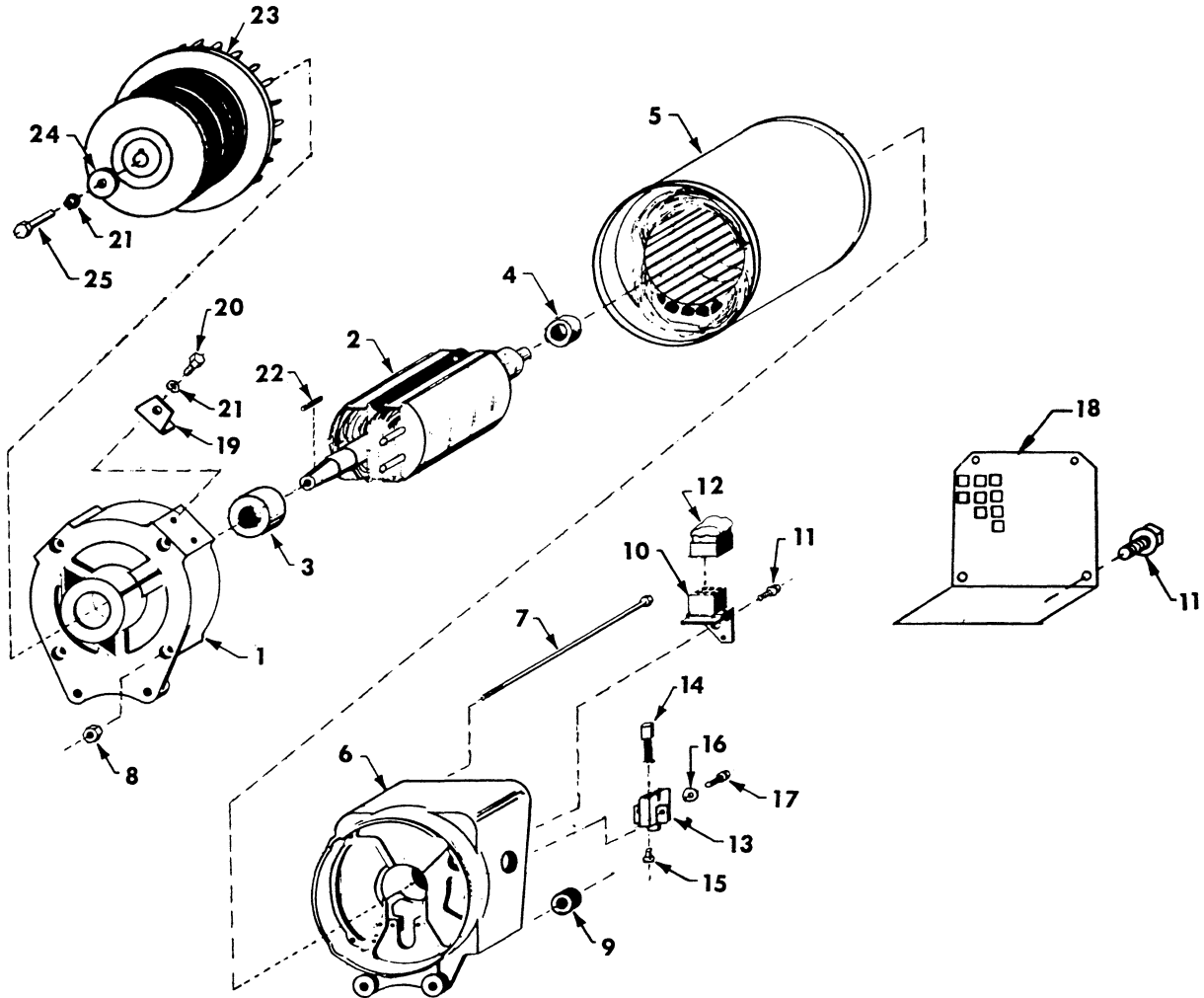

Item	Part No.	Req'd	Description
1	42-04-0420	1	Front Bearing Carrier
2	23-40-0350	1	Rotor Assembly
3	02-04-2600	1	Bearing
4	02-04-5030	1	Bearing
5	23-58-0410	1	Stator Assembly
6	43-76-0350	1	Rear Bearing Carrier
7	06-75-0071	4	Indented Hd. Capscrew, 11 3/8 Lg.
8	06-55-1100	4	10-32 "Lock-ut" Hex nut
9	22-90-0120	1	Rubber Grommet
10	45-60-0250	1	Rectifier Support Assembly
11	06-81-0030	7	10-32 x 3/8 Lg. Taptite Screw
12	23-38-2630	1	Rectifier Assembly
13	22-20-0220	1	Brush Holder
14	22-18-0340	2	Brush Assembly
15	02-81-8650	2	6-32 x 1/4 Lg. Rd. Hd. Screw & L.W.
16	45-88-7195	2	10 Flat Washer
17	06-81-3640	2	8-32 x 5/8 Lg. Taptite Screw
18	45-03-0115	1	Air Inlet Screw
19	42-36-0685	1	Support Bracket
20	06-75-0300	2	5/16-18 x 3/4 Lg. Hex Hd. Capscrew
21	06-97-4100	5	5/16 Lockwasher
22	06-42-3700	1	3/16 Square Key
23	22-84-0455	1	Fan Pulley
24	45-88-7200	1	Flat Washer (special)
25	06-75-0351	1	5/16-24 x 1 1/4 Lg. Hex Hd. Capscrew
26	45-12-0265	1	Alternator Fan Guard (Not Shown)

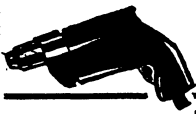

# SERVICE PARTS LIST

**BUL. 54-00-0930**

## 7000 WATT ALTERNATOR

REVISED BUL. DATE  
June '70

**Catalog No. 4790**

Starting Serial No. **439-1001**

WIRING INSTR. **54-00-0950**

Both Model and Serial No. must be furnished to obtain correct parts.

For Engine Replacement Parts or Service, Refer to Manufacturers Name Plate and Contact their Nearest Service Center.

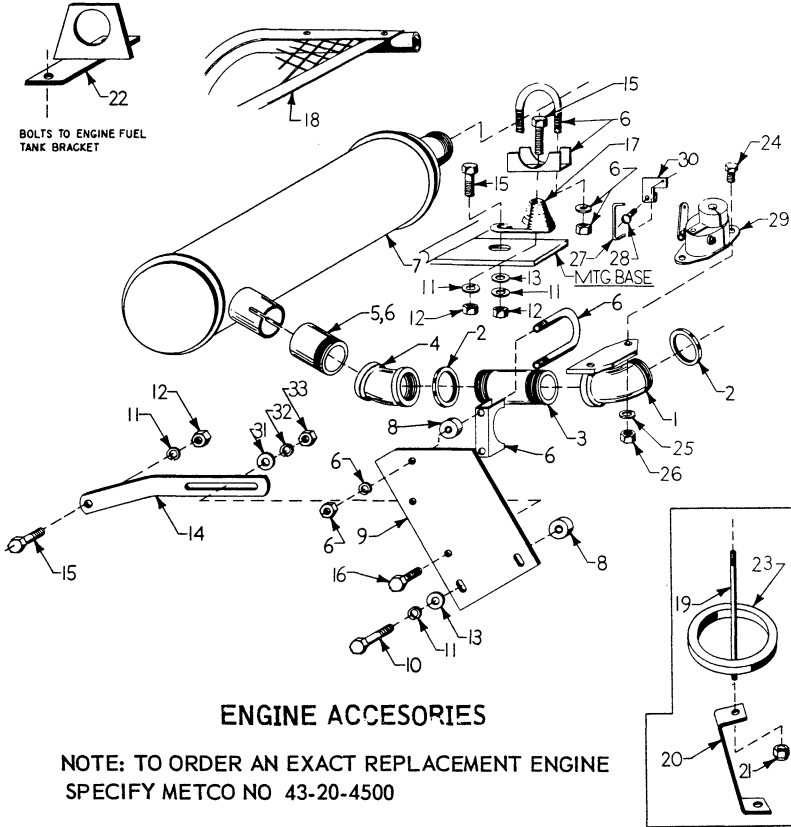

Item	Part No.	Req'd	Description
1	44-66-5270	1	Choke Mounting Plate Assembly
2	06-57-7500	2	1 1/4 N.P.T. Pipe Locknut
3	43-33-0400	1	1 1/4 N.P.T. x 1/2 Lg. Nipple
4	43-33-0420	1	1 1/4 N.P.T. x 45° Elbow
5	43-33-0410	1	1 1/4 N.P.T. x 1 3/4 Lg. T.O.E. Nipple
6	42-68-0260	3	Muffler Clamp Assembly
7	43-31-0250	1	Muffler (Stainless Steel)
9	44-66-5280	1	Muffler Support Plate
10	06-75-0343	2	5/16-18 x 2 1/2 Lg. Stressproof Capscrew
11	06-97-4100	5	5/16 Lockwasher - Split
12	06-55-1980	3	5/16-18 Hex. Nut
13	45-88-5245	3	5/16 Flat Washer
14	45-56-0120	1	Adjusting Strap
15	06-75-0340	3	5/16-18 x 1" Lg. Hex. Hd. Capscrew
16	06-75-0500	2	3/8-16 x 1" Lg. Hex. Hd. Capscrew
17	40-50-6900	1	Spring
18	43-54-0230	1	Muffler Guard
19	06-92-2510	1	Air Cleaner Stud
20	45060-0280	1	Air Cleaner Support
21	06-57-5005	1	1/4-28 Locknut
22	42-36-0690	1	Lifting Eye
23	06-85-1740	4	10 Sheet Metal Screw
24	06-75-0100	2	1/4 x 3/4 Lg. Hex. Hd. Capscrew
25	06-97-1000	2	1/4 Lockwasher
26	06-55-1500	2	1/4-20 Hex Nut
27	44-94-0180	1	Choke Control Rod
28	06-81-8650	1	6-32 x 1/4 Lg. Sems Sc. & L.W.
29	43-44-0310	1	Automatic Choke & Gasket
30	42-68-0270	1	Choke Lever Clamp
31	45-88-5261	1	3/8 Flat Washer
32	06-97-4125	2	3/8 Lockwasher
33	06-55-2400	2	3/8-16 Hex Nut

### ENGINE ACCESSORIES

NOTE: TO ORDER AN EXACT REPLACEMENT ENGINE SPECIFY METCO NO 43-20-4500

### LOW OIL SHUT-OFF SYSTEM

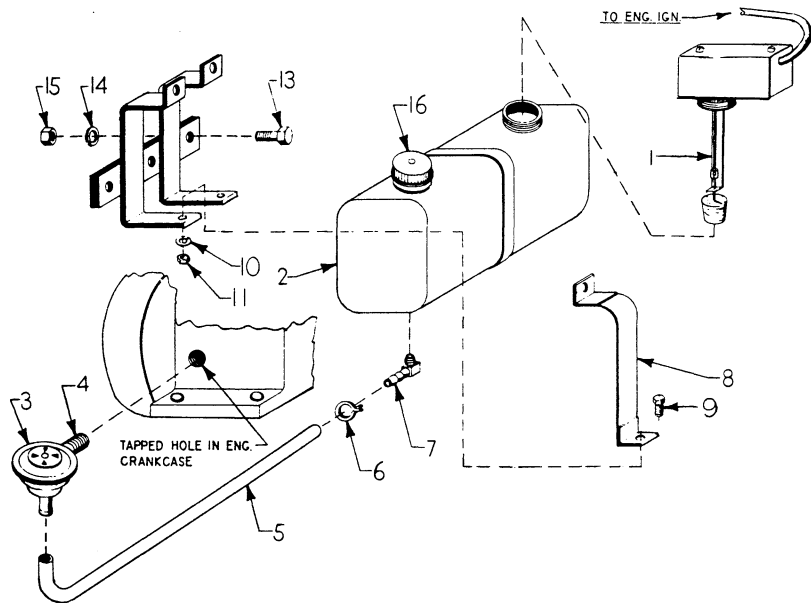

Item	Part No.	Req'd	Description
1	23-66-0850	1	Low Oil Shut-off Switch Assembly
2	45-66-0060	1	Oil Tank
3	43-64-0101	1	Pump Head Assembly
4	43-33-0320	1	Probe Assembly
5	45-76-0170	1	Rubber Hose
6	42-68-0280	1	Hose Clamp
7	43-33-0330	1	90° Tank Outlet
8	45-56-0130	2	Oil Tank Strap
9	06-75-0150	4	1/4-20 x 1" Lg. Hex. Hd. Capscrew
10	06-97-1000	4	1/4 Lockwasher - Split
11	06-55-1500	4	1/4-20 Hex Nut
12	45-60-0290	1	Oil Tank Support Assembly
13	06-75-0340	2	5/16-18 x 1" Lg. Hex. Hd. Capscrew
14	06-97-4100	2	5/16 Lockwasher - Split
15	06-55-1980	2	5/16-18 Hex Nut
16	42-52-0210	1	Filler Cap



# SERVICE PARTS LIST

BUL. 54-00-0940

## 7000 WATT ALTERNATOR

REVISED BUL  DATE June '70

Catalog No. **4790**

Starting Serial No. **439-1001**

WIRING INSTR. **54-00-0950**

Both Model and Serial No. must be furnished to obtain correct parts.

### BATTERY MOUNTING ASSEMBLY

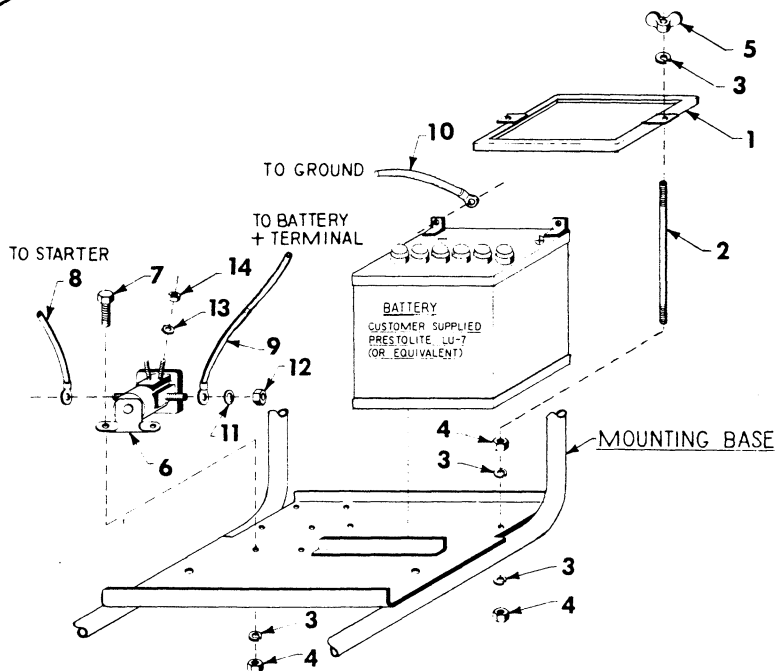

Item	Part No.	Req'd	Description
1	44-80-0160	1	Battery Tie-Down Rack
2	06-92-0505	2	1/4-20 Stud
3	06-97-1000	8	1/4 Lockwasher
4	06-55-1500	6	1/4-20 Hex. Nut
5	06-59-2000	2	1/4-20 Wing Nut
6	23-84-0050	1	Starter Solenoid
7	06-75-0100	2	1/4-20 x 3/4 Lg. Hex. Hd. Capscrew
8	22-64-0670	1	Wire Assembly (91)
9	22-64-0670	1	Wire Assembly (90)
10	22-64-0680	1	Wire Assembly (10)
11	06-97-4100	2	5/16 Lockwasher
12	06-55-1995	2	5/16-24 Hex. Nut
13	06-97-0870	2	10 Shakeproof Lockwasher - Ext.
14	06-55-1100	2	19-32 Hex. Nut

### DOLLIE KIT

ITEMS 8, 9 AND 10 ARE RE-USED FROM MOUNTING BASE FASTENERS SUPPLIED WITH UNIT

Item	Part No.	Req'd	Description
1	42-12-0050	1	Dollie Axle Assembly
2	45-94-0110	2	Wheel
3	34-60-2260	2	Snap Ring
4	06-75-0600	4	3/8-16 x 1 3/4 Lg. Hex. Hd. Capscrew
5	06-97-4125	6	3/8 Lockwasher
6	06-55-2400	6	3/8-16 Hex. Nut
7	44-04-0060	1	Dollie Support Leg
8	06-75-0340	4A	5/16-18 x 1" Lg. Hex. Hd. Capscrew
9			Item 9, 10 Supplied with unit; reuse for dollie kit
10			
11	45-88-5245	4	5-16 Flat Washer
12	43-33-0300	2	Rubber Vibration Dampener
13	45-88-5261	2	3/8 Flat Washer
14	43-62-0490	1	Dollie Handle
15	06-75-0344	4	5/16-18 x 2 1/2 Lg. Hex. Hd. Capscrew
16	06-97-4100	6A	5/16 Lockwasher - Split
17	06-55-1980	6	5/16-18 Hex. Nut
18	06-75-0525	2	3/8-16 x 1 1/4 Lg. Hex. Hd. Capscrew

