



Operating Instructions and Parts Manual SLT-330F Scissor Lift Table



WALTER MEIER (Manufacturing) Inc.

427 New Sanford Road
LaVergne, Tennessee 37086
Ph.: 800-274-6848
www.waltermeier.com

Part No. M-140771
Revision B 11/2010

Copyright © 2010 Walter Meier (Manufacturing) Inc.

Warranty and Service

Walter Meier (Manufacturing) Inc., warrants every product it sells. If one of our tools needs service or repair, one of our Authorized Service Centers located throughout the United States can give you quick service. In most cases, any of these Walter Meier Authorized Service Centers can authorize warranty repair, assist you in obtaining parts, or perform routine maintenance and major repair on your JET® tools. For the name of an Authorized Service Center in your area call 1-800-274-6848.

MORE INFORMATION

Walter Meier is consistently adding new products to the line. For complete, up-to-date product information, check with your local Walter Meier distributor, or visit waltermeier.com.

WARRANTY

JET products carry a limited warranty which varies in duration based upon the product (MW = Metalworking, WW = Woodworking).

90 DAY WARRANTY	1 YEAR WARRANTY	Body Repair Kits Bottle Jacks Cable Pullers Cold Saws Hoists-Air Hoists-Electric Metal forming Mill/Drills Milling Machines MW Bandsaws MW Drill Presses MW Finishing Equipment MW Lathes MW Precision Vises	2 YEAR WARRANTY	Palet Trucks Rigging Equip. Service Jacks Stackers Surface Grinders Tapping Trolleys-Air Trolleys-Electric Web Slings Winches-Electric	3 YEAR WARRANTY	WW Benchtop Tools	5 YEAR WARRANTY	Beam Clamps Chain Hoist- Manual Lever Hoists Pullers-JCH Models Scissor Lift Tables Screw Jacks Trolleys-Geared Trolleys-Plain Winches-Manual WW Air Filtration WW Bandsaws WW Buffers	WW Drill Presses WW Dust Collectors WW Dust Filters WW Dust Fittings WW Jointers WW Lathes WW Planers WW Sanders WW Shapers WW Tablesaws	LIFE LIFETIME WARRANTY	Fastening Tools Mechanics Hand Tools Striking Tools Vises (no -precision) Clamps
Warranty reverts to 1 Year Warranty if woodworking (WW) products listed above are used for industrial or educational purposes.											

WHAT IS COVERED?

This warranty covers any defects in workmanship or materials subject to the exceptions stated below. Cutting tools, abrasives and other consumables are excluded from warranty coverage.

WHO IS COVERED?

This warranty covers only the initial purchaser of the product.

WHAT IS THE PERIOD OF COVERAGE?

The general JET warranty lasts for the time period specified in the product literature of each product.

WHAT IS NOT COVERED?

Five Year Warranties do not cover woodworking (WW) products used for commercial, industrial or educational purposes. Woodworking products with Five Year Warranties that are used for commercial, industrial or education purposes revert to a One Year Warranty. This warranty does not cover defects due directly or indirectly to misuse, abuse, negligence or accidents, normal wear-and-tear, improper repair or alterations, or lack of maintenance.

HOW TO GET SERVICE

The product or part must be returned for examination, postage prepaid, to a location designated by us. For the name of the location nearest you, please call 1-800-274-6848.

You must provide proof of initial purchase date and an explanation of the complaint must accompany the merchandise. If our inspection discloses a defect, we will repair or replace the product, or refund the purchase price, at our option. We will return the repaired product or replacement at our expense unless it is determined by us that there is no defect, or that the defect resulted from causes not within the scope of our warranty in which case we will, at your direction, dispose of or return the product. In the event you choose to have the product returned, you will be responsible for the shipping and handling costs of the return.

HOW STATE LAW APPLIES

This warranty gives you specific legal rights; you may also have other rights which vary from state to state.

LIMITATIONS ON THIS WARRANTY

WALTER MEIER (MANUFACTURING) INC., LIMITS ALL IMPLIED WARRANTIES TO THE PERIOD OF THE LIMITED WARRANTY FOR EACH PRODUCT. EXCEPT AS STATED HEREIN, ANY IMPLIED WARRANTIES OR MERCHANTABILITY AND FITNESS ARE EXCLUDED. SOME STATES DO NOT ALLOW LIMITATIONS ON HOW LONG THE IMPLIED WARRANTY LASTS, SO THE ABOVE LIMITATION MAY NOT APPLY TO YOU.

WALTER MEIER SHALL IN NO EVENT BE LIABLE FOR DEATH, INJURIES TO PERSONS OR PROPERTY, OR FOR INCIDENTAL, CONTINGENT, SPECIAL, OR CONSEQUENTIAL DAMAGES ARISING FROM THE USE OF OUR PRODUCTS. SOME STATES DO NOT ALLOW THE EXCLUSION OR LIMITATION OF INCIDENTAL OR CONSEQUENTIAL DAMAGES, SO THE ABOVE LIMITATION OR EXCLUSION MAY NOT APPLY TO YOU.

Walter Meier sells through distributors only. The specifications in Walter Meier catalogs are given as general information and are not binding. Members of Walter Meier reserve the right to effect at any time, without prior notice, those alterations to parts, fittings, and accessory equipment which they may deem necessary for any reason whatsoever. JET®-branded products are not sold in Canada by Walter Meier.

Warnings

1. Read and understand the owner's manual before assembly and operation.
2. Do not load scissor lift beyond its rated capacity.
3. Do not allow people to sit or ride on scissor lift.
4. Always secure load in center of table before raising, lowering or moving scissor lift.
5. Do not transport loads in the raised position.
6. Use on smooth, level, finished floors only.
7. Pull release lever fully to allow load to descend in a controlled manner.
8. Keep hands and feet clear of table when lowering load.
9. Failure to comply with the above warnings may result in personal injury and/or property damage.

Specifications

Model Number.....	SLT-330F
Stock Number	140771
Capacity (lbs)	330
Table Size, L x W (in).....	27-1/2 x 17-3/4
Maximum Height (in).....	28-3/4
Minimum Height (in).....	8-5/8
Handle Height (in).....	34-1/8
Strokes (without load) to Reach Maximum Height	16
Wheel Diameter (in.).....	5
Overall Length (in).....	36
Net Weight (lbs).....	91
Shipping Weight (lbs).....	99

The above specifications were current at the time this manual was published, but because of our policy of continuous improvement, Walter Meier reserves the right to change specifications at any time and without prior notice, without incurring obligations.

Operation

Note: The scissor lift table comes pre-assembled and ready to use. However, during transit air may have seeped into the pump. To bleed air out of the hydraulic system, raise and lower the table several times to work any air bubbles out of the pump.

1. The table is raised by pumping the foot lever (B, Figure 1).
2. To lower the table, slowly pull the release lever fully. This allows the table to lower in a slow, controllable manner.
3. Before loading, always lock the caster brake by pressing the lock (A, Figure 1).

Folding Handle

1. Lower the table.
2. Push the rod (C, Figure 1) back.
3. Fold the handle flat across the table.

Maintenance

1. Lubricate each friction point monthly with #2 tube grease.
2. Check the movement and wear of wheels.
3. Check for oil leakage from the hydraulic cylinder. Add hydraulic oil as needed.
4. Always store with table in lowered position when not in use.

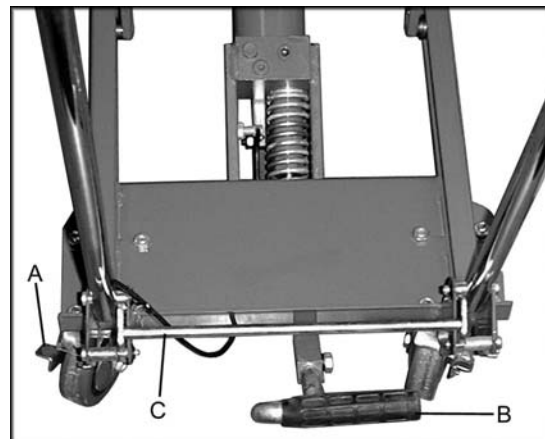

Figure 1

Troubleshooting

Numbers in parentheses refer to index numbers in the parts breakdown.

Trouble	Probable Cause	Remedy
Table will not rise.	No oil in pump reservoir.	Replenish pump reservoir.
	Lowering valve (22) or steel ball (21) is not seating.	Clean lowering valve (22) or steel ball (21) or replace.
	Steel ball (16) is not seating.	Clean or replace steel ball (16).
Table will not remain elevated.	Lowering valve (22) or steel ball (21) is not seating.	Clean or replace lowering valve (22) or steel ball (21).
	Oil seal (5) or U-packing (7) is worn out.	Replace oil seal (5) or U-packing (7).
Table will not lower.	U-packing (7) is worn out.	Replace U-packing (7).
	Lowering valve plug (22) is clogged.	Replace lowering valve plug (22).
Oil leaks from lowering valve.	O-ring (27) is worn out.	Replace O-ring (27).
Oil leaks from pump cylinder.	Oil seal (31) or U-packing (32) is worn out.	Replace oil seal (31) or U-packing (32).

Replacement Parts

Replacement parts are listed on the following pages. To order parts or reach our service department, call 1-800-274-6848, Monday through Friday (see our website for business hours, www.waltermeier.com). Having the Model Number and Serial Number of your machine available when you call will allow us to serve you quickly and accurately.

Breakdown for SLT-330F Hydraulic Scissor Lift

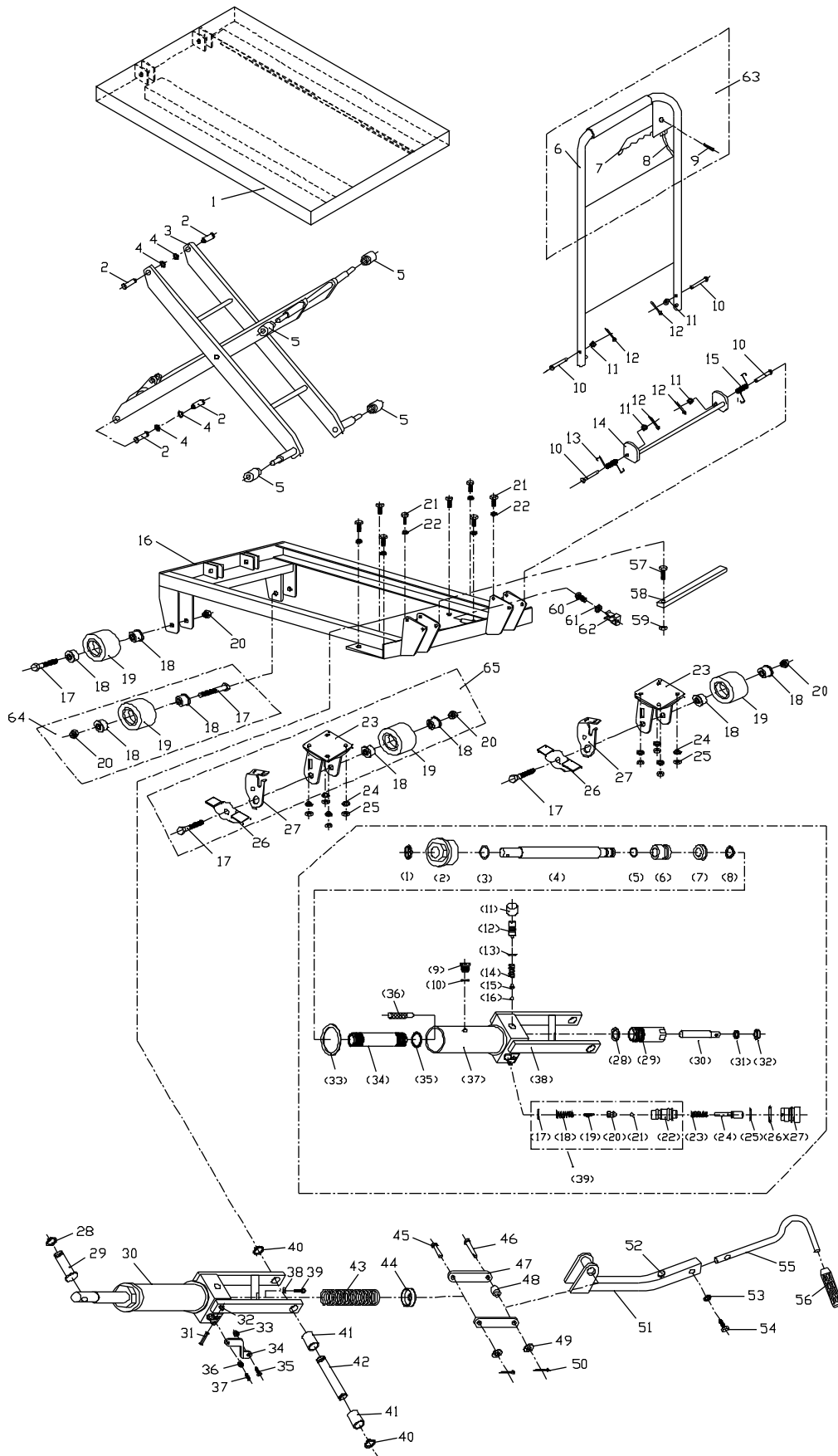

Parts List for SLT-330F Hydraulic Scissor Lift

Index No.	Part No.	Description	Size	Qty
1	SLT330F-01	Table		1
2	SLT330F-02	Link Shaft		4
3	SLT330F-04	Link Assembly		1
4	SLT330F-03	C-Ring	Ø 12 mm	4
5	SLT330F-05	Roller Guide		4
6	SLT330FH-06	Handle		1
7	SLT330FH-07	Release Lever		1
8	SLT330FH-08	Cable		1
9	SLT330FH-09	Spring Pin	Ø 6 x 22 mm	1
10	SLT330FH-10	Lock Pin		4
11	SLT660F-66	Washer	Ø 8 mm	4
12	SLT660FH-14	Split Pin	Ø 3 x 20 mm	4
13	SLT330FH-13	Spring A		1
14	SLT330FH-14	Foot Lever		1
15	SLT330FH-15	Spring B		1
16	SLT330FH-16	Frame		1
17	SLT330FH-17	Hex Cap Screw	M12 x 65	1
18	SLT330FH-18	Nonstandard Bearing		8
19	SLT330FH-19	Wheel	4"	4
20	TS-2342121	Lock Nut	M12	4
21	TS-1490031	Hex Cap Screw	M8 x 20	8
22	TS-1550061	Washer	Ø 8 mm	6
23	SLT330FH-23	Swivel Wheel Holder		2
24	TS-1550061	Washer	Ø 8 mm	8
25	TS-1541031	Lock Nut	M8	8
26	SLT330FH-26	Brake Plate		2
27	SLT330FH-27	Stop Support		2
28	SLT330F-03	C-Ring	Ø 12 mm	1
29	SLT330F-24	Shaft		1
30	SLT330FH-30	Hydraulic Pump Assembly		1
[1]	SLT3300F-26-1	Oil Seal*	DHS25	1
[2]	SLT330F-26-2	Top Nut		1
[3]	SLT330F-26-3	O-Ring*	Ø 31 x 3.5 mm	1
[4]	SLT330F-26-4	Lift Piston		1
[5]	SLT330F-30-5	O-Ring*	Ø 14 x 2.4 mm	1
[6]	SLT330F-26-5	Piston Bushing		1
[7]	SLT330F-26-7	U-Packing*	D30	1
[8]	SLT330F-26-8	C-Ring	Ø 18 mm	1
[9]	SLT330F-26-9	Air Breather		1
[10]	SLT330F-26-10	O-Ring*	Ø 11x1.9 mm	1
[11]	SLT330F-26-11	Relief Plug Cover		1
[12]	SLT330F-26-13	Relief Adjusting Screw		1
[13]	SLT330F-26-10	O-Ring*	Ø 11 x 1.9 mm	1
[14]	SLT330F-26-14	Spring		1
[15]	SLT330F-26-15	Steel Ball Support		1
[16]	SB-5MM	Steel Ball	Ø 5 mm	1
[17]	SLT330FH-30-17	Valve Cap		1
[18]	SLT330FH-30-18	Spring		1
[19]	SLT330FH-30-19	Helix Valve		1
[20]	SL330FH-30-20	Cone Valve		1
[21]	SLT330FH-30-21	Steel Ball	Ø 6.35 mm	1
[22]	SLT330FH-30-22	Valve		1
[23]	SLT330FH-30-23	Spring		1
[24]	SLT330FH-30-24	Adjusting Shaft		1
[25]	SLT330F-26-23	O-Ring*	Ø 14 x 2.4 mm	1
[26]	SLT330FH-30-26	O-Ring	Ø 16 x 2.4 mm	1

Index No.	Part No.	Description	Size	Qty
[27]	SLT330FH-30-27	Bonnet		1
[28]	SLT330FH-30-28	Inner Washer		1
[29]	SLT330F-26-30	Pump Cylinder		1
[30]	SLT330F-26-34	Pump Piston		1
[31]	SLT330F-26-33	Oil Seal*	UHS18	1
[32]	SLT330F-26-32	U-Packing*	DHS18	1
[33]	SLT330F-30-33	Outer Washer*		2
[34]	SLT330FH-30-34	Inside Cylinder Tube		1
[35]	SLT330FH-30-35	Inside Washer*		1
[36]	SLT330FH-30-36	Filter		1
[37]	SLT330FH-30-37	Outer Cylinder Tube		1
[38]	SLT330FH-30-38	Pump Body		1
[39]	SLT330FH-30-39	Valve Assembly (Index # [17] thru [22])		1
31	SLT330FH-31	Pin		1
32	SLT330FH-32	C-Ring	Ø 8 mm	1
33	TS-2311081	Hex Nut	M8	1
34	SLT330FH-34	Platen		1
35	SLT330FH-21	Hex Cap Screw	M8 x 20	1
36	TS-2311081	Hex Nut	M8	1
37	SLT330FH-37	Socket Set Screw	M8 x 30	1
38	TS-2311081	Hex Nut	M8	1
39	SLT330FH-39	Hex Cap Screw	M8 x 30	1
40	SLC660F-38	C-Ring	Ø 20 mm	2
41	SLT330FH-41	Bushing		1
42	SLT330FH-42	Shaft		1
43	SLT330F-37	Spring		1
44	SLT330F-38	Spring Cover		1
45	SLT330FH-45	Pin		1
46	SLT330FH-46	Pin		1
47	SLT330F-39	Slide Plate		2
48	SLT330F-42	Bushing		1
49	SLT330FH-49	Washer	Ø 10 mm	2
50	SLT660FH-63	Split Pin	Ø 3 x 30 mm	2
51	SLT330F-44	Lever		1
52	SLT330FH-52	Rubber Bumper		1
53	TS-2361081	Spring Washer	Ø 8 mm	1
54	TS-1490051	Hex Cap Screw	M8 x 30	1
55	SLT330F-48	Foot Lever		1
56	SLT330F-49	Foot Lever Pad		1
57	SLT660FH-70	Hex Cap Screw	M10 x 30	1
58	SLT330FH-58	Safety Bar		1
59	SLT660FH-72	Hex Nut	M10	1
60	SLT660FH-73	Hex Cap Screw	M6 x 10	1
61	SLT660FH-74	Spring Washer	Ø 6 mm	1
62	SLT660FH-75	Spring Clip		1
63	SLT330FH-63	Handle Assembly (index # 6 thru 9)		1
64	SLT330FH-64	Front Wheel Assembly (index # 17 thru 20)		1
65	SLT330FH-65	Swivel Wheel Assembly (index # 17-20,23,26-27)		1
	SLT330FH-RK	Repair Kit		1

Index Numbers in brackets are part of the Hydraulic Pump Assembly, SLT330FH-30.

Parts included in the repair kit are indicated by an asterisk *.

TEST CERTIFICATE

COMMODITY	Scissor Lift Table
MODEL	SLT-330F
SERIAL NO.	
CAPACITY	330 lbs
TEST LOAD	lbs
DATE OF INSPECTION	
JUDGEMENT	PASSED
INSPECTOR	



WALTER MEIER (Manufacturing) Inc.

427 New Sanford Road
LaVergne, Tennessee 37086
Phone: 800-274-6848
www.jettools.com
www.waltermeier.com