



SERVICE PARTS LIST

BULLETIN NO.
54-26-7010

SPECIFY CATALOG NO. AND SERIAL NO. WHEN ORDERING PARTS		REVISED BULLETIN	DATE
CORDLESS 7/16" QUICK CHANGE IMPACT WRENCH			Oct. 2011
CATALOG NO. 0799-20	STARTING SERIAL NO. A97A & A97B	WIRING INSTRUCTION SEE REVERSE SIDE	

Slug placement is for both handle halves.

Replace the Gasket (37) whenever the tool is opened for servicing.

EXAMPLE:
Component Parts (Small #) Are Included When Ordering The Assembly (Large #).

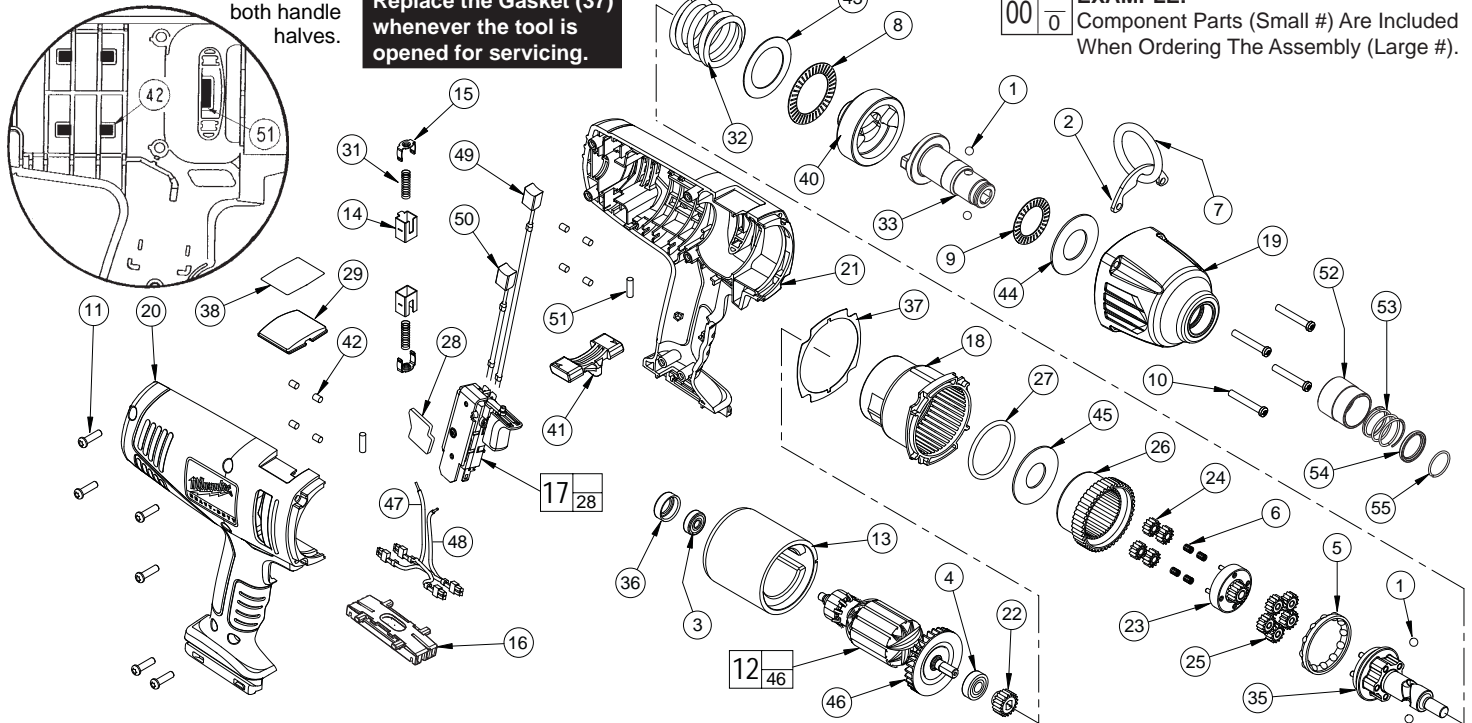

FIG.	PART NO.	DESCRIPTION OF PART	NO.REQ.
1	02-02-0250	1/4" Ball	(4)
2	43-72-0275	Tool Hanger	(1)
3	02-04-0645	Ball Bearing	(1)
4	02-04-0852	Ball Bearing	(1)
5	02-40-0050	Angular Contact Bearing	(1)
6	02-50-3260	Unit Cage Bearing	(4)
7	44-90-0095	Steel Ring	(1)
8	02-80-0200	Thrust Bearing	(1)
9	02-80-3256	Thrust Bearing	(1)
10	05-88-5988	K50 x 35mm Screw	(4)
11	06-95-6290	M5 x 2.24 x 18 Plastite Screw	(7)
12	16-01-2120	Armature	(1)
13	18-01-2120	Field	(1)
14	22-20-0425	Brush Tube	(2)
15	22-32-0420	Brush Spring Clip	(2)
16	22-56-0975	Connector Block Assembly	(1)
17	23-66-1779	Switch Assembly	(1)
18	28-14-0175	Gearcase	(1)
19	14-38-0100	Front Housing Assembly	(1)
20	31-44-0179	Right Handle	(1)
21	31-44-0779	Left Handle	(1)
22	32-60-0170	Sun Gear	(1)
23	32-60-0185	Sun Gear	(1)
24	32-62-0210	Planet Gear	(4)
25	32-62-0215	Planet Gear	(5)
26	32-65-0005	Ring Gear	(1)
27	34-40-0070	O-Ring	(1)
28	23-50-0120	Rubber Spacer	(1)
29	31-01-0779	Label Plate	(1)
31	40-50-9079	Spring	(2)
32	40-50-0241	Spring	(1)
33	14-73-0175	Anvil	(1)
35	14-73-0300	Cam Shaft Assembly	(1)
36	42-96-0015	Bearing Cup	(1)
37	43-44-0991	Gasket	(1)
38	12-20-1799	Service Nameplate Kit	(1)
40	44-82-0205	Ram	(1)
41	45-24-0640	Reversing Shuttle	(1)
42	45-30-0021	Rubber Slug	(8)
43	45-88-0535	Washer	(1)
44	45-88-1575	Washer	(1)
45	45-88-3250	Washer	(1)
46	22-84-0375	Fan	(1)
47	23-94-0279	Leadwire Assembly-Black	(1)
48	23-94-0179	Leadwire Assembly-Red	(1)
49	22-18-2080	Brush Assembly-Red	(1)
50	22-18-1980	Brush Assembly-Black	(1)
51	45-30-0025	Rubber Slug	(2)
52	42-76-0185	Collar	(1)
53	40-50-0365	Spring	(1)

FIG.	PART NO.	DESCRIPTION OF PART	NO.REQ.
54	44-90-0020	Spring Support	(1)
55	34-60-0050	Retaining Ring	(1)

FIG. 3 NOTES:
Orient bearing seal (black side) toward the commutator.

10 Torque to 32-42 in./lbs.

11 Torque to 15-25 in./lbs.

12,14,21 Remove brush tubes prior to removing armature assembly from left handle half.

12,14,21 Install brush tubes into left handle half after armature assembly has been secured into that handle half.

16,28 Concave side of connector block cover to face connector block.

17,21 Ensure that the field is firmly seated on the locking groove on the left handle half prior to installing the right handle half. The field should not be able to rotate.

49,50 At the time of brush replacement, the tool should be relubricated with Type "Z" Grease, No.49-08-7655.

FIG. 19,26,35,40 LUBRICATION (Type "Z" Grease, No.49-08-7655):
Lightly coat with grease the Ring Gear (26) and the Camshaft Planet Carrier bearing races (35). Lightly coat with grease the back bearing surface of the Ram (40) and the I.D. of the Front Housing Bushing (19).

23,24,25,35 Fill with grease the center of the five Planet Gears (25) on the Camshaft Assembly (35). Fill the center of the four Planet Gears (24) on the Sun Gear (23).

40 Place approximately 1/4 oz. of grease in the front cavity of the Ram.

35 Place approximately 1/4 oz. grease on the Camshaft (35) inside the Spring (32).

MILWAUKEE ELECTRIC TOOL CORPORATION
13135 W. LISBON RD., BROOKFIELD, WI 53005

ROUTE THE RED BRUSH ASSEMBLY LEADWIRE #49 THROUGH THE WIRE TRAPS, AS SHOWN.

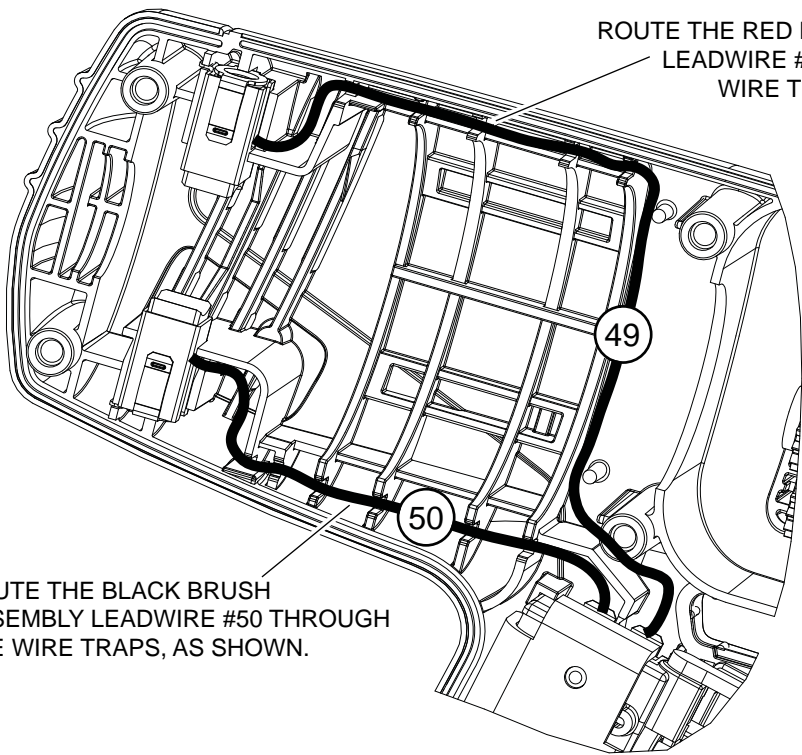

ROUTE THE BLACK BRUSH ASSEMBLY LEADWIRE #50 THROUGH THE WIRE TRAPS, AS SHOWN.

BRUSH ASSEMBLIES 49 AND 50 ARE TO BE SOLDERED TO THE SWITCH, AS SHOWN

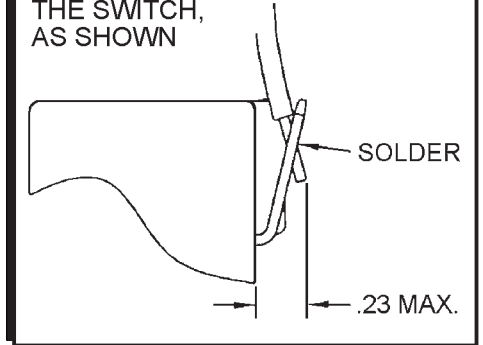

CONNECT THE TERMINALS OF LEADWIRE ASSEMBLIES 47 AND 48 TO THE TABS ON THE BOTTOM OF THE SWITCH AND SOLDER.

⚠ WARNING
SWITCH POLARITY SENSITIVE
 If wired incorrectly with connector block #16, switch #17 **will be** damaged and destroyed!

ROUTE THE LEADWIRES BETWEEN THE POSTS.

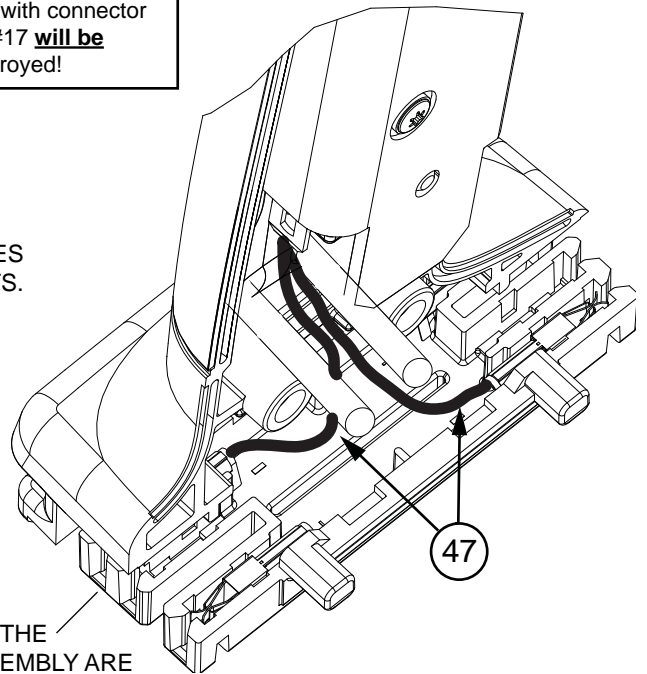
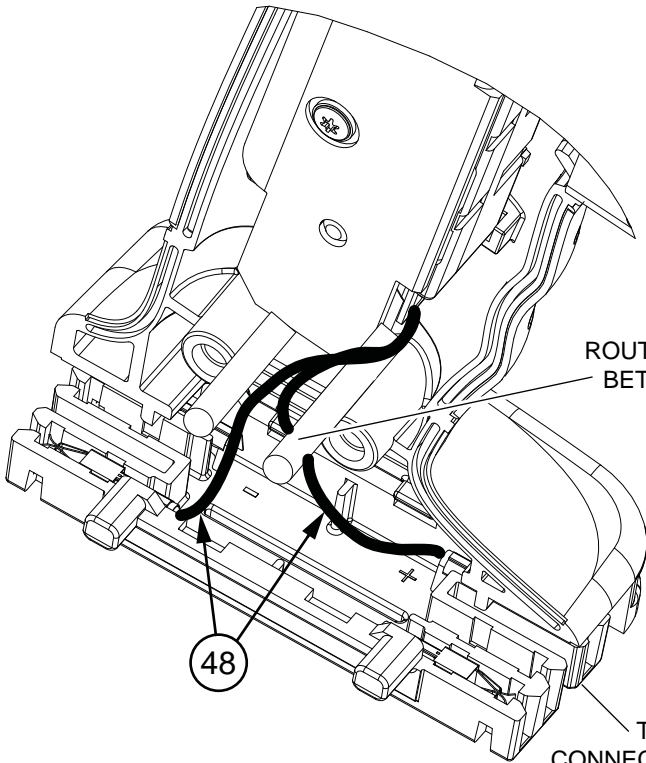

THESE VIEWS OF THE CONNECTOR BLOCK ASSEMBLY ARE SHOWN WITHOUT THE CONNECTOR BLOCK COVER FOR CLARITY.

WIRING SPECIFICATIONS

TERMINAL DESCRIPTION

Wire No.	Wire Color	Origin or Gauge	Length	Terminals, Connectors and 1 or 2 End Wire Preparation
47	Black	23-94-0279	-----	Leadwire Assembly.
48	Red	23-94-0179	-----	Leadwire Assembly.
49	Red	22-18-2080	-----	Carbon Brush Assembly - Red
50	Black	22-18-1980	-----	Carbon Brush Assembly - Black

Code	Part No.	Qty.